

HIGH-CAPACITY INTERNET NETWORKS FOR RESEARCH AND EDUCATION COMMUNITIES

A TEIN3 workshop co-organised by the Ministry of Post and Telecommunication (MPT), the Ministry of Education and Sports (MOES) and the National University of Laos (NUOL) with DANTE under the aegis of the European Commission

EVENT AGENDA (CLICK ON SPEAKERS' NAMES TO ACCESS THEIR PRESENTATIONS)

09:00 OPENING SESSION

Master of Ceremony

- ★ Welcome & Opening address from Dr. Sisamone Sithirajvongsa, Permanence Secretary, MOES
- ★ Welcome speech from Michel Goffin, Attaché, Delegation of the European Union to Lao PDR
- ★ Keynote speech from **ByungKyu Kim**, Executive Officer, TEIN* Cooperation Center
- ★ Opening remark from **Sengdeuane Lachanthaboun**, Vice Minister, MOES

TEA / COFFEE BREAK

11:00 SESSION 1: SHARING KNOWLEDGE AND EXPERIENCE

Chaired by Sigma Orionis

- ★ ASEAN-EU Year of Science
 - **Simon Grimley**, SEA-EU-NET
- ★ Practicable steps to develop a NREN Network
 - **Dale Smith**, NSRC
- ★ Presentations from other Southeast Asian NRENs
 - **Chalermpol Charnsripinyo**, NECTEC/THAIREN
 - **Nguyen Hong Van**, NASATI/VINAREN

BUFFET LUNCH

14:00 SESSION 2: PROMISING APPLICATIONS

- ★ Lao IT/ICT Development
 - **Khamla Sounalath**, LANIC, MPT
- ★ LERNET vision regarding connection to TEIN3
 - Dr.Phonekeo Chanthamaly ITC, NUOL
- ★ Status of use of ICT Education in Lao PDR
 - **Dr.Somkiat Phasy**, MOES

TEA / COFFEE BREAK

16:00 INTERACTIVE FORUM

Chaired by Sigma Orionis, MOES, MPT, NUOL

- ★ Open interaction with the audience (Q&A, next steps)
- ★ Wrap-up by MPT/MOES and TEIN* Cooperation Center

NETWORKING DRINKS



MPT



Vientiane,
Lao PDR
May 28, 2012
Lao Plaza Hotel

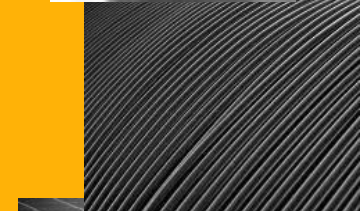

Co-Prosperity of Asia and Europe through Digital Silk Road



TEIN3 Southeast Asia Workshops

Vientiane, Lao PDR

28 May 2012



ByungKyu Kim, Ph.D.
Executive Officer
TEIN* Cooperation Center

Research Networks

- providing new opportunities for global collaborations in all fields -

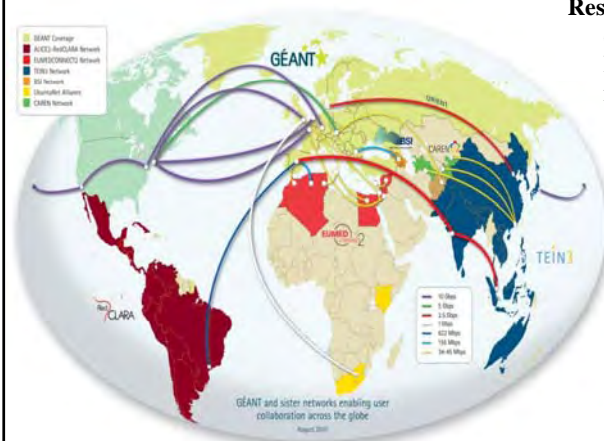

Research networking started since early 1990's to offer high speed, high quality Internet connections for research and education:

- National level, run by NRENs (normally publicly funded)
- Increasing regional level networks e.g. TEIN connecting all European and Asian countries, and major academic and research centres
- During last 5- 10 years emergence of inter-regional links for global co-operations

TEIN (Trans-Eurasia Information Network) provides regional and global links for Asian researchers.

Beginning of TEIN

- TEIN Initiative @ ASEM3 (October 2000) -



“Partnership for Prosperity and Stability in the New Millennium”



- ◆ Contribute to enhancing exchanges and cooperation between Asia and Europe through increased and more effective information flows;
- ◆ Enhance and diversify research exchanges and cooperation between Asia and Europe;
- ◆ Expand and diversify speedier and more powerful telecommunication connections between Asia and Europe

Brief History & Evolution of TEIN



2000 TEIN Initiative endorsed @ ASEM3 (Seoul)

2001 TEIN KR-FR launched (2Mbps)
TEIN quoted as “the basis of a strong partnership b/w Asia & Europe” @ ASEM4 (Copenhagen)

2003 TEIN KR-FR upgraded to 45M

2006.03, TEIN3 Outline Proposal by DANTE – extended to South Asia partners

2006.09, TEIN2 Launch Event (*press conference*) @ ASEM6 Summit (Helsinki)

2009.12, ASEM/TEIN3 Workshop (KL) – KR Statement for TEIN*CC proposal

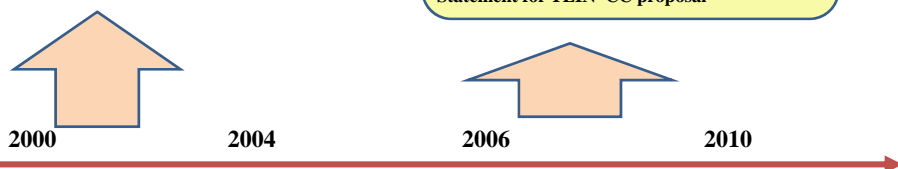

2000

2004

2006

2010

2004.01 TEIN2 announced by EU, funding 10M Euro esp. for ASEM-Asia(SEA) partners

2004.12 TEIN1(KR-FR) upgraded to 155M

2006.01 TEIN2 launched, *TEIN1* closed and replaced with *TEIN2*

2010.05, TEIN4 Outline Proposal by DANTE and Korea – toward self-sustainable in Asia

2010. 10, TEIN4 and TEIN*CC endorsed @ ASEM8 Summit (Brussels)

TEIN 3



- TEIN3 provides a large-scale research and education data-communications network for the Asia-Pacific region since 2006.
 - Extends and encourages research and education IP connectivity, linking Asia-Pacific researchers, educators and students to each other and to their counterparts in Europe.
 - Via fast, direct links to Europe's multi-gigabit GÉANT network and North America, providing the Asia-Pacific countries with a gateway for global collaboration..

TEIN3 Network

- 18 Asian partners (12 receiving EC funding support)
- 45M+ connected users
- 4 hubs: Mumbai, Singapore, Hong Kong, Beijing
- Fastest Internet links for research within Asia
- Fastest and highest capacity direct Internet links for research with Europe
- 11.4M Euro EC funding (65% co-funding)
- Non-commercial

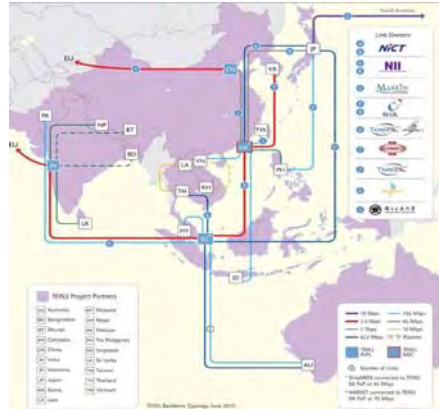

Key Applications



- TEIN3 success stories:
 - Natural disaster warning and post-crisis support
 - Crop research
 - Tele-surgical training
 - Medical tele-consultations
 - Virtual lectures
 - e-Social Science

TEIN3 saves lives
TEIN3 allows accurate typhoon forecasting and life-saving weather warnings through timely transfer of meteorological data from Germany to the Philippines.

TEIN3 tackles wildfires
TEIN3 helps get the right information to the right people to detect dangerous hotspots and track active wildfires in Indonesia.

TEIN3 trains doctors
Surgeons at their hospitals to learn surgical techniques from world experts through interactive remote training.

TEIN3 fights hunger
Grow crops with greater yields and analyze growing conditions faster.

An ASEM Success Story *is continued*



- ASEM3 Summit (Seoul, 2000) endorsed TEIN as one of the new 16 ASEM Initiatives upon the co-proposal by Korea, Singapore and European Commission

“Under the theme of “Partnership for Prosperity and Stability in the New Millennium”



- The success of TEIN2 was celebrated at the ASEM6 Summit in Finland, which marks the tenth anniversary of ASEM (Asia-Europe Meeting) co-operation, **“10 Years of ASEM: Global Challenges – Joint Responses”**.

“Collaboration between Europe and Asia is increasingly critical to solving global issues, such as climate change and health threats such as avian influenza and HIV/AIDS.”

“TEIN2 is bridging the digital divide within Asia-Pacific, and it is already delivering opportunities and benefits to the citizens of both regions. We expect this success to continue as it expands.”

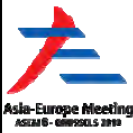

- ASEM8 Chair’s Statement for TEIN4 and TEIN* Cooperation Center (<http://www.asem8.be/sem-8-chairs-statement-and-brussels-declaration>), October 2010

- (page 18) 79. Leaders recognized the important role played by the Trans-Eurasian Information Network (TEIN) project in increasing direct internet connectivity among research and education in Asia and between Asia and Europe. **They welcomed the planned launch of its 4th phase and the establishment of a Cooperation Center hosted by the Republic of Korea with financial contributions from participating ASEM partners.**

TEIN4 & TEIN* Cooperation Center



- In the ASEM8 Summit in Brussels on October 2010, the Leaders endorsed **TEIN4 and the establishment of the TEIN* Cooperation Center** in its Chair’s Statement.
- TEIN* Cooperation Center (TEIN*CC) was established on August 2011 in Seoul, South Korea. It is a non-profit Foundation Corporation governed by the Korean Civil Act.
- Supports from EC, KCC, Seoul Metropolitan City
 - Operational costs by KCC (Korea Communications Commission)
 - TEIN4 programme (8M Euro/48months) by the EC
 - Seoul Metropolitan City provides the TEIN*CC office and office facilities

- TEIN4 contract signed between EC and TEIN*CC on April 2012.

- The 1st Governors’ Meeting and TEIN*CC Opening Ceremony in Seoul (May 2012)



TEIN4 Launch Event is planned
 during the ASEM9 Summit (Vientiane, Laos, 5-6 November 2012)



TEIN4 Launch Event will be held in Laos on November 2012.



The 9th Asia-Europe Meeting Summit or ASEM 9 will be held on 5 - 6 November 2012 in Vientiane, Lao PDR under the theme: **"Friends for Peace, Partners for Prosperity"**. It will provide yet another important occasion for Leaders of Asia and Europe to discuss regional and international issues of common interest and concern, including, among others, food and energy security, sustainable development, financial and economic crisis, climate change, natural disaster response, socio-cultural cooperation and future direction of ASEM.

TEIN4 Partners

Beneficiary partners (13 countries)

- Bangladesh** : University Grants Commission (UGC)
- Bhutan** : Department of Information Technology and Telecom (DIT&T)
- Cambodia** : Institute of Technology of Cambodia (ITC)
- India** : National Knowledge Network (NKN), Education and Research Network (ERNet)
- Indonesia** : Institut Teknologi Bandung (ITB)/INHERENT
- Laos** : Lao Education and Research Network (LERNet)
- Malaysia** : Malaysian Research and Education Network (MYREN)
- Nepal** : Nepal Research and Education Network (NREN)
- Pakistan** : Pakistan Education and Research Network (PERN)
- Philippines** : Advanced Science and Technology Institute (ASTI)
- Sri Lanka** : Lanka Education and Research Network (LEARN)
- Thailand** : Thailand Research Education Network Association (ThaiREN)
- Vietnam** : National Agency for Science and Technology Information (NASATI)

Non-Beneficiary partners (5 countries)

- Australia** : Australia, Academic and Research Network (AARNet)
- China** : China Education and Research Network (CERNet), Hong Kong Academic and Research Network (HARNet)
- Japan** : National Institute of Information and Communications (NICT), National Institute of Informatics (NII), Ministry of Agriculture, Forestry and Fisheries Research Network (MAFFIN)
- Korea** : National Information Society Agency (NIA)
- Singapore** : Singapore Advanced Research & Education Network (SingAREN)

Further country National Research and Education Networks (NRENs) may join during the course of TEIN4.



TEIN4 Objectives



❑ Overall objective

To contribute to the MDGs (Millennium Development Goals) by establishing dedicated high-capacity internet links between Research and Education (R&E) organisations in the Asia-Pacific region and Europe, enabling and promoting collaborative research on applications of broad societal benefit.

❑ Specific objectives

- ❖ To further develop dedicated high-speed internet links between national R&E organisations in Asia and connect them with Europe.
- ❖ To promote the broadening of MDG relevant user applications made available by the TEIN network, and increase the use of the TEIN network.
- ❖ To enhance human capacity of the TEIN4 beneficiary partners and promote international R&E collaboration between Asian and European partners.



TEIN4 Work Packages



❑ WP1 - Network Procurement and Commercial Management

- ❖ Conducting TEIN4 network tender, TEIN4 NOC tender
- ❖ Sourcing TEIN4 network equipment
- ❖ Reviewing NOC performance & overseeing the TEIN4 NOC
- ❖ Conducting a feasibility study



❑ WP2 - Promoting and Supporting Applications

- ❖ Developing a portfolio of target applications areas for TEIN4 support
- ❖ Developing tools and technical support to facilitate application deployment on TEIN4
- ❖ Setting up a TEIN4 user support group to co-ordinate applications support and share best practice
- ❖ dissemination activities

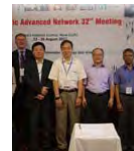

❑ WP3 - Enhancing Human Capacity and International Collaboration

- ❖ Commissioning and delivering customized training courses on network engineering and operations
- ❖ Providing funding support, subject to budget availability, for beneficiaries' staff capacity development
- ❖ Assessing needs for non-technical training by beneficiary partners
- ❖ Enhancing the cooperation with other parties in facilitating R&E developments in Asia



Open Discussions for NREN in Lao PDR



“High-Capacity Internet networks for Research and Education Communities”

- ❑ How to further develop the NREN in Lao PDR, to strengthen cooperation between NRENs in the region, and to ensure their full integration into TEIN3
- ❑ Which applications could take the greatest benefit of the potential of NRENs: e-learning and education, emerging diseases, agriculture and crop research, etc.
- ❑ The next steps needed to implement identified perspectives, namely through the next TEIN phase: TEIN4



Thank you.

bkkim@teincc.org

- ❖ TEIN*CC Staff : staff@teincc.org
- ❖ TEIN*CC Website : www.teincc.org

**TEIN 3 Workshop
28th May, 2012, Vientiane, Lao PDR**

**Opening Remark
By
Sengdeuane LACHANTHABOUN
Vice Minister of Education and Sports**

Distinguished guests,

Ladies and Gentlemen,

It is a great honor and pleasure to be invited to the International TEIN 3 Workshop which is taking place in Lao PDR and hosted by Ministry of Education and Sports under cooperation of Ministry of Post and Telecommunication, and under technical, financial assistances and cooperation of International organizations: EU, DANTE, Sigma Orionis and Southeast Asia-Europe. In this regards, on behalf of Ministry of Education and Sports and Ministry of Post and Telecommunication, it is pleased to express our sincerely thanks full and appreciation to EU, and organizations related with TEIN project giving good opportunity to organize today workshop and thanks and appreciation to all organizers for their kind supports and full efforts devoting to organization of this workshop.

On this auspicious occasion, please allow me to warmly welcome all delegates and participants from various organizations within Laos and abroad.

In order to The Government of Lao PDR Policy has clearly identified that Education is the core of Human Resource Development – a key factor influencing the National Socio-Economic Development which must be growth towards industrialization and modernization. In these regards, Government of Lao PDR Policy and Strategy Documents acknowledge that long run economic development is a requirement for substantial reform to the National Education System that become a top priority for Education Sector Development.

In order to lead the country from a situation of less developed country in the year 2020 towards industrialization and modernization, and to move from emerging to applying, infusing and transforming ICT stages in education that is required National Education System Reform, the Government has emphasized that ICTs) is potentially powerful enabling tools for educational change and reform. Therefore, in this regards, using Government budget and different international technical and financial assistances, the Government has been investing in some national physical ICT infrastructure and human IT resource as you may know from different sources, especially, in recognition for the immediate as well as long term needs and priorities defined by Education Policy of

the Government and the extended efforts for education sector, Ministry of Education and Sports develop and implement different projects on use of ICT in general to improve the quality of and access to education, particularly, in order to lay the information and communication technology foundation to aid the development on the improvement of ICT Infrastructure for Education Sector; the quality of education services; the education administration and management capability; human resource development and capacity building and furthermore, research and education network. The implementation of those projects for the intranet at national level will be based on the Government Backbone.

Ministry of Education and Sport gives high values and contribution to national ICT development for education to National University of Laos in being a member to TEIN, Since 2006, has attempted to act as a representative to Lao Education and Research Network (or LERNET), or RE-ISP that is not only to implement the commitment to ASEM, but bring physical improvement for the quality of education and research that are promoted the international research and education network collaboration. Regarding this matter, please allow me to congratulate and appreciate such achievements and express thanks to EU, DANTE and National University of Laos for valuable work and contribution to Lao National Development.

In order to further develop and promote the effectiveness, compactness and closeness of Research and Education Network Cooperation (or RE Network) among Asian and European countries, and strengthen realize the activities of this kind of collaboration of Research and Education among Asian and European country, we are here together to present perspectives projects and to share and learn from experiences through this one day practical workshop.

I am very confident that upon the completion of this workshop, we will have a concrete and effective solution to further develop and strengthen Research and Education Network Cooperation (or RE Network) among Asian and European countries.

On this occasion, on behalf of Lao Government as well as Ministry of Education and Sports and Ministry of Post and Telecommunication I would like to thank for all valuable contributions of experts of DANTE and financial support from EU.

I would also like to wish all the delegates and participants good luck, good health and have a great success and would like at this moment to officially open this workshop.

Thank you for your attention

ASEAN-EU Year of Science, Technology and Innovation 2012



Outline

- What is NSTDA
- ASEAN-EU Scientific Cooperation
- What is FP7
- SEA-EU-NET Project
- Lessons learned
- ASEAN-EU Year of Science, Technology and Innovation



NSTDA – who we are



- Leading applied R&D agency in Thailand
- Staff ~2,600, 68% in R&D with ~400PhDs
- Annual operating budget 115 M-USD from the Government (including construction)
 - 20% from contracts, services and licenses
- Work in 4 broad technology areas - nano, biotech, ICT and materials – 4 National Centers
- 94 research labs
- Also provide external research funding



Completion 2013

Growth of ASEAN – EU Scientific Cooperation



ASEAN from an EU perspective

- 600 million people / ~9% of the world's population live in Southeast Asia
- Population expected to grow to over 700 million by 2030
- very dynamic, diverse region
- Regional integration – AEC 2015
- The EU's fifth most important trading partner
- S&T excellence is developing fast!

Unique richness of Biodiversity	One of the regions most vulnerable to Climate Change
Major food producer (Rice production)	Hotspot for emergence of infectious diseases and drug resistance



Growth Thailand Scientific Publications

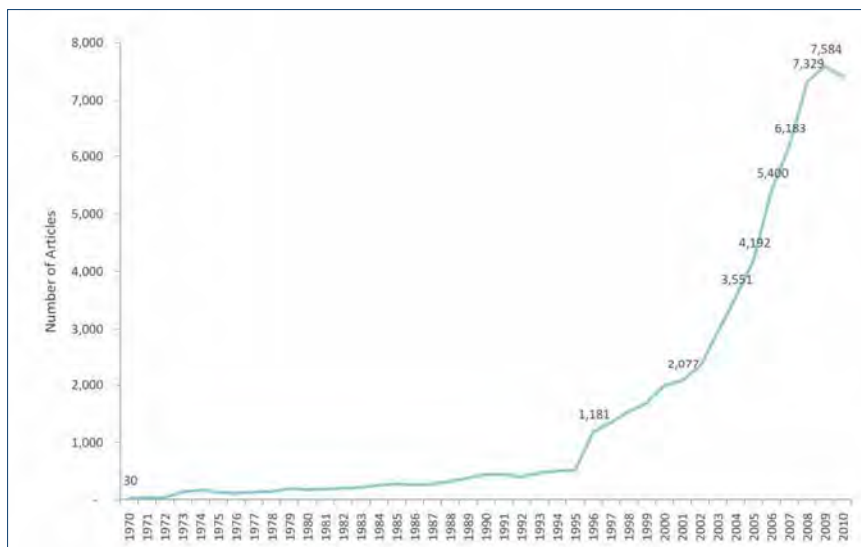

Source: Scopus data compiled by the Office of the Higher Education Commission, Thailand (OHEC)

ASEAN-EU co-publication output

Articles co-published by authors from ASEAN and EU,
and ASEAN and other major players

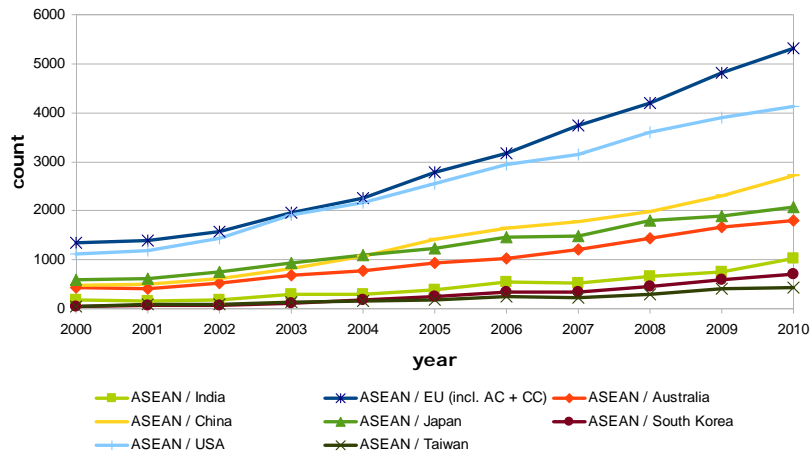

Thailand - EU Cooperation

- over 30 years bilateral relations
- 4x increase in scientific publications in 10 years
- Tripled contribution to the number of scientific publications worldwide
- 1998 Thailand and the EU had 200 co-published research papers
- In less than 10 years this had climbed to 700 co-publications



What is FP7



7th European Framework Programme (FP7)

- Biggest pan-European programme for research and innovation
- 2007-2013, budget €54 billion
- Support for individual researchers, fellowships, consortia, academia, companies,...
- Bulk of program is “ top down“ (project themes are given)
- Open to the world
 - *EU Member States*
 - *Associated Countries (Norway, Switzerland, Turkey, Israel,...)*
 - *3rd Countries (entitled for funding, no funding)*
- Almost all of FP7 open to participation by ASEAN researchers!



ASEAN Participation in FP7

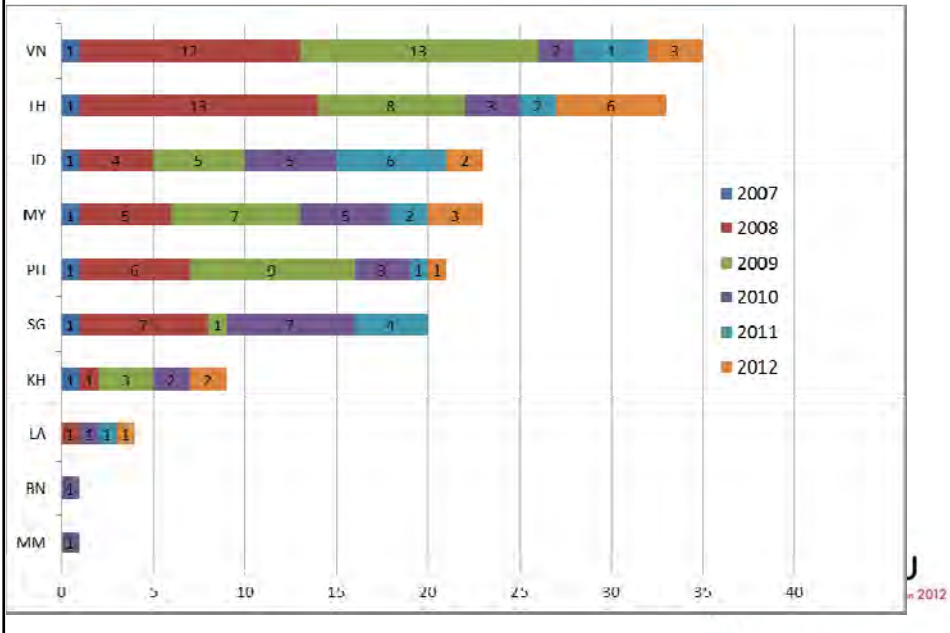

Thailand FP7 Participation at a glance

- 196 submitted participations in 156 proposals
- 33 successful projects with 40 participants
- Success rate: 20% (EU mean value: 22%)
- € 4 million funding to Thai researchers since the start of FP7 in 2007



SEA-EU-NET Project



SEA-EU-NET Project

- Project funded by FP7 to foster S&T cooperation between Europe and South East Asia
- Objectives:
 - stakeholders dialogue
 - increasing participation of researchers from ASEAN in FP7
 - scientific analyses and recommendations
- one of ten running INCONETs (major world regions)
- 22 partner organisations in EU and ASEAN (10 partners from Europe, 3 from associated countries and 9 from Southeast Asia)
- Run by policy makers and science administrators



SEA-EU-NET Lessons learnt

1. Stakeholder dialogue:

- Stakeholder conferences are an effective informal forum for dialogue between multi-sectoral and multi-disciplinary stakeholders
- Useful platform to link different bi-regional and bilateral initiatives (Creating synergies between EU and SEA member states initiatives)
- Challenging to organise a conference that is of interest for very different groups of stakeholders (Policy makers, administrators, scientists)
- Very good experiences in sharing the responsibility for the conferences among different partners
- Official political dialogue open for input from INCO projects (esp. for analysis/recommendations)



SEA-EU-NET Lessons learnt

2. FP7 participation, NCP establishment:

- FP7 National contact points in SEA are key to reach out to SEA research community – project has built a regional network
- Positive experience in organising NCP meetings/trainings linked to publication of FP7 calls (mid-of the year)
- FP7 is not an “easy sell” (no ASEAN-specific priorities, “global competition”, collaborative research in big teams, high entrance barrier)
- Very difficult to translate priority setting (recommendations for topics) into action (“SICA calls”)
- FP7 alone is not sufficient (esp. to strengthen cooperation with weaker ASEAN countries) – FP cooperation has to be set in a wider context (mobility schemes, long-term institutional cooperation)
- Bilateral cooperation strengthened



SEA-EU-NET Lessons learnt

3. Analysis:

- Major objectives:
 - Increase knowledge among EU policy makers (and scientists) about dynamics of Innovation systems in SEA
 - Increase visibility of S&T cooperation between the two regions
- Strong analysis is key to be able to convince policy makers about the necessity to strengthen bi-regional cooperation
- Need to provide both qualitative and quantitative analysis (and interlink them)
- Offers great opportunities to collaborate with other stakeholders (OECD, UNESCO, APEC Foresight Centre, etc..)
- Timing is important: Publication/presentation of major studies during Stakeholder conferences



ASEAN-EU Year of Science Technology and Innovation 2012



Introduction to the ASEAN-EU Year of Science Technology and Innovation

- An idea born within the SEA-EU-NET project, based on the project's dialogue activities
- A year long campaign to deepen S&T collaboration between Europe and Southeast Asia
- Officially endorsed by the ASEAN Committee of Science and Technology (COST) and the European Commission/DG RTD



The Objectives

- Coordinate joint S&T-related events
- Raise awareness among the public, and especially the young, about the importance of S&T cooperation
- Promote Southeast Asian and European competencies in S&T
- Establish a platform for the mobility of ideas and researchers and stimulate research partnerships
- Identify common global research challenges and ways to tackle them
- Develop and launch new funding instruments to support SEA-EU S&T cooperation



The Objectives (2)

- Strengthen a high level political dialogue between the two regions in support of S&T cooperation
 - Highlight the diversity of S&T relations between the two regions and give impetus to future joint activities
 - Promote closer ties between the peoples of Southeast Asia and Europe
- To date, **31 events planned** in 10 different countries from the two regions, with more than 30 different institutions from both regions involved



Three Main Axes

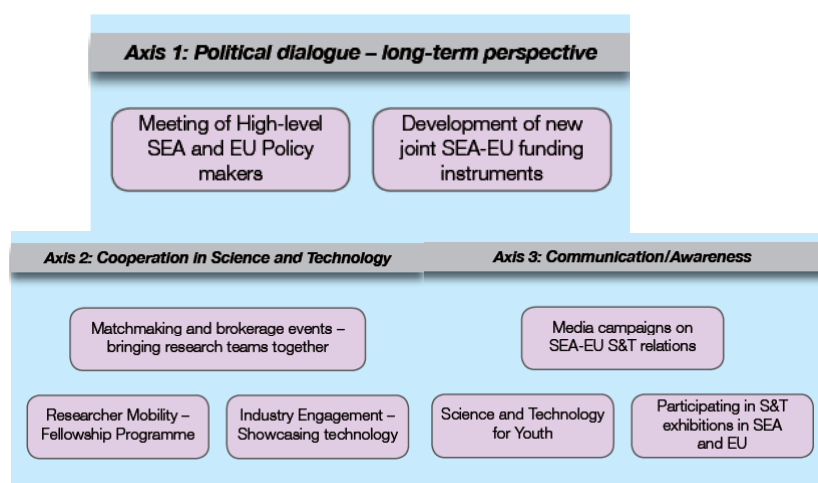

Activities - Four Pillars

Pillar 1: SEA-EU-NET-led and funded Activities/events

Pillar 2: EC and ASEAN-led initiatives

Pillar 3: Ongoing Multilateral activities/events labelled under the ASEAN-EU YoSTI

Pillar 4: Bilateral activities/events of ASEAN and EU member states

Thank you

More information

- ASEAN-EU Year of Science www.yearofscience2012.com
- SEA-EU-NET project www.sea-eu.net

Simon Grimley
International Cooperation Division
NSTDA
www.nstda.or.th
simon@nstda.or.th



Practical Steps to Building an NREN

Dale Smith

Network Startup Resource Center

dsmith@nsrc.org

This document is a result of work by the Network Startup Resource Center (NSRC at <http://www.nsrc.org>). This document may be freely copied, modified, and otherwise re-used on the condition that any re-use acknowledge the NSRC as the original source.



Research and Education Networks

- Some Terminology
 - Research and Education = R&E
 - Research and Education Networks = REN
 - National REN = NREN
- Almost every developed country around the world has built a National Research and Education Network (NREN)
- Why?



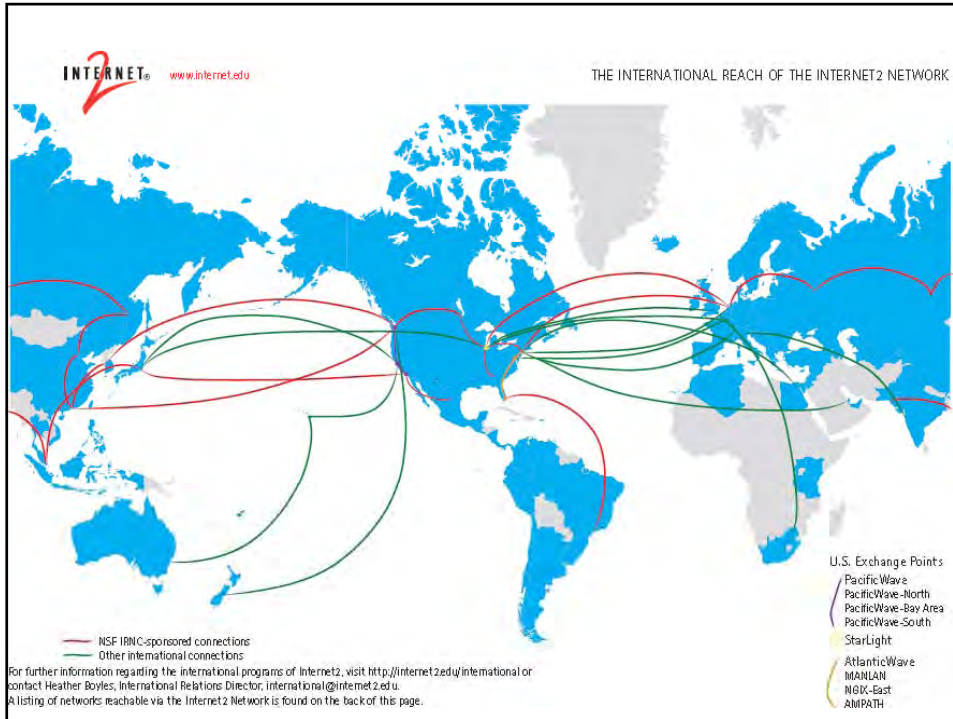

Why an NREN?

- Develop networking capacity to support Research and Education
- Build a community that is a forum for collaboration
- Successful RENs find that there are unanticipated benefits
- Why not just buy Internet Access from an Internet Service Provider?

Why not Commercial Providers

- High bandwidth networks
 - Advanced R&E networks have 10Gbs backbones with some doing 40Gbs and 100Gbs
 - Research typically needs uncongested networks
- Open Networks with no filtering
- Commercial Providers can do this
 - A few NRENs are operated by Providers
 - The barrier is cost. Most successful NRENs are operated by Universities, not Providers



NREN Challenges

- NSRC works throughout the world with many emerging NRENs
- Many NRENs have three challenges:
 - Some don't make effective use of their R&E connectivity
 - Campus Networks are not adequate
 - Some don't provide general Internet access



Don't Make Effective use of R&E

- This is a technical issue, but very common
- The problem is that when there are two paths (Internet and Research and Education) from the NREN to another site, how is the path chosen?
 - Default configuration won't always prefer the Research and Education network.



Inadequate Campus Networks

- Many are not structured properly and can't effectively utilize high bandwidth REN connections
- Many make heavy use of NAT and firewalls that limit performance
- Many are built with unmanaged network equipment that provide no ability for monitoring or tuning the network
- Many don't have sufficiently trained staff



NREN Not Providing Internet

- Two basic NREN models:
 1. NREN is Peering network
 - No access to the Commercial Internet
 - Exchange traffic between members
 - Provide international connections to other RENs
 2. NREN provides all Internet connectivity
 - Provides access to the Commercial Internet
 - Also exchanges traffic between members
 - Provides international connections to other RENs
 - The REN is the Internet Service Provider



NREN as Peering Network

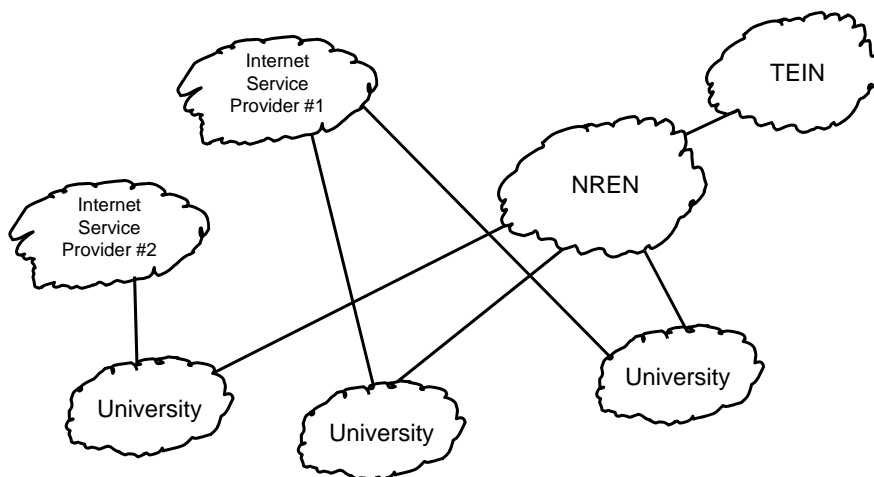

NREN as ISP

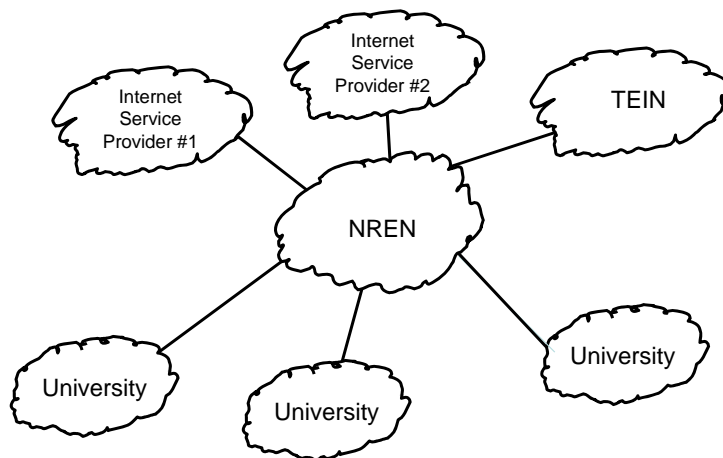

Implications for Universities

- If NREN is a Peering Network
 - Each University still has their own ISP
 - Each University connects to NREN
 - The two connections are hard to manage
- If NREN provides all Internet connectivity
 - Simplest for campus members
 - Treats NREN as Internet Service Provider
 - Only one connection to manage



NREN as a Peering Network

- Easiest to implement from a political perspective.
 - The Internet Service Providers like this approach because they keep many customers
 - Often the legal and regulatory environment allows this use without licensing and/or the license is easier to get
- However, there are problems with this approach



NREN as a Peering Network

- Universities now have two connections
 - How do they decide which one to use?
- Three approaches:
 1. Get provider independent IP address, autonomous system number, and run BGP
 2. Get routes from NREN and run special software and configuration on a NAT box
 3. Split campus network into NREN and Internet
- What do we find around the world?



NRENs Around the World

- Most NRENs act as the Internet Service Provider
- There are two classes of Peering Only
 - Advanced regions: they do the right thing and have Provider Independent IP addresses, ASN, and run BGP. This works fine.
 - Less advanced regions: they split their campus and the NREN becomes a video conferencing network.
- What kind of network will you build here?



Closing Thoughts

- How will you structure your Research and Education Network strategy?
- If you build an NREN
 - Consider providing consulting services to members to address inefficient campus networks
 - Consider providing Internet access as part of the NREN



Questions/Discussion?

This document is a result of work by the Network Startup Resource Center (NSRC at <http://www.nsrc.org>). This document may be freely copied, modified, and otherwise re-used on the condition that any re-use acknowledge the NSRC as the original source.



Development of Thailand Research Educational Network for Global Collaboration

Sharing Knowledge and Experience in TEIN3 Workshops

By Chalernpol Charnsripinyo

NECTEC/ThaiREN



Development of Research & Education Networks in Thailand

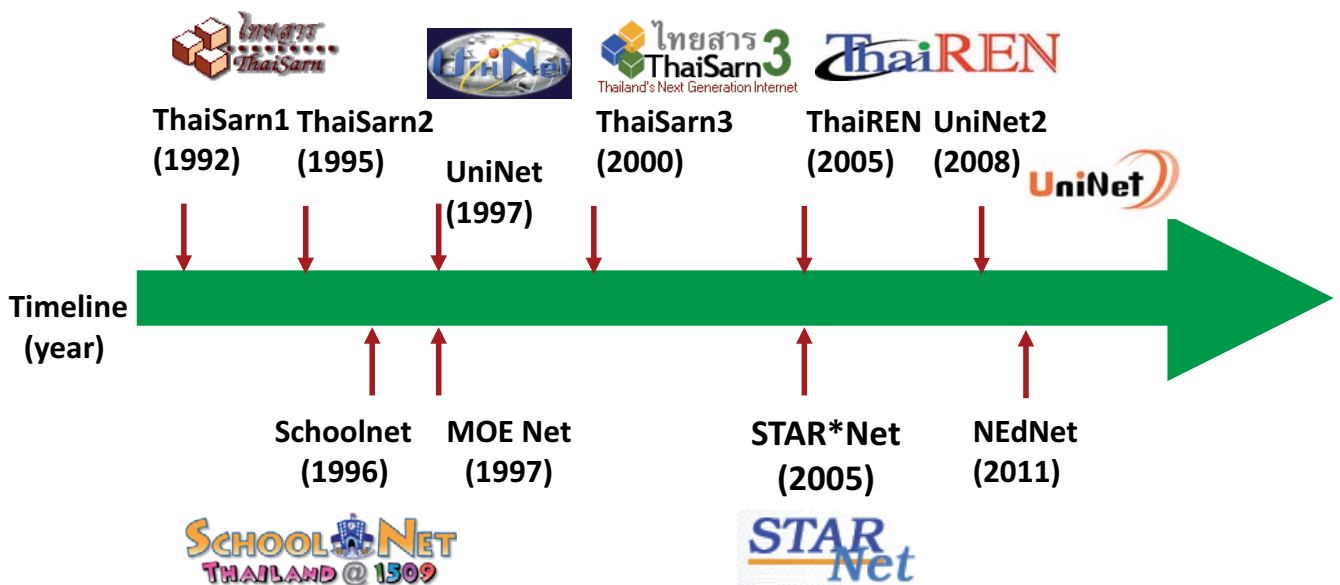

➤ ThaiREN is established to coordinate among research and education networks in Thailand as well as collaborate with international R&E networks.

Beginning of Thai R&E Network

ThaiSarn Status (April 23, 1992)

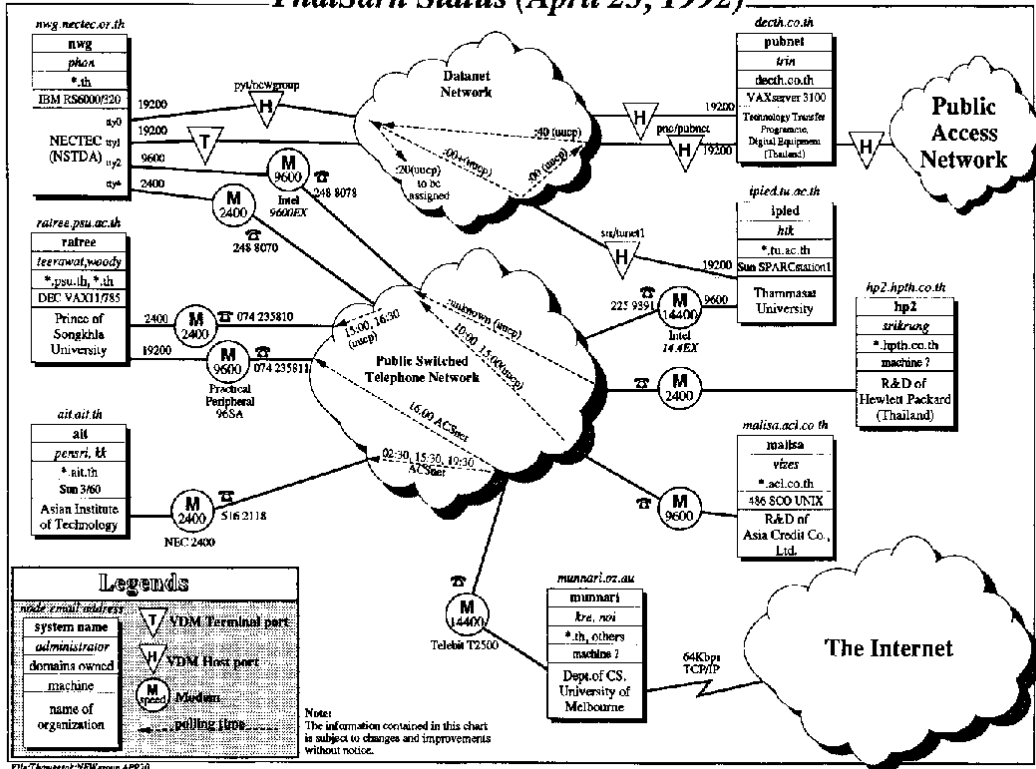

[Information Source: <http://www.nsrc.org/ASIA/TH/thaisarn.gif>]

ThaiSarn Network (Y1995)

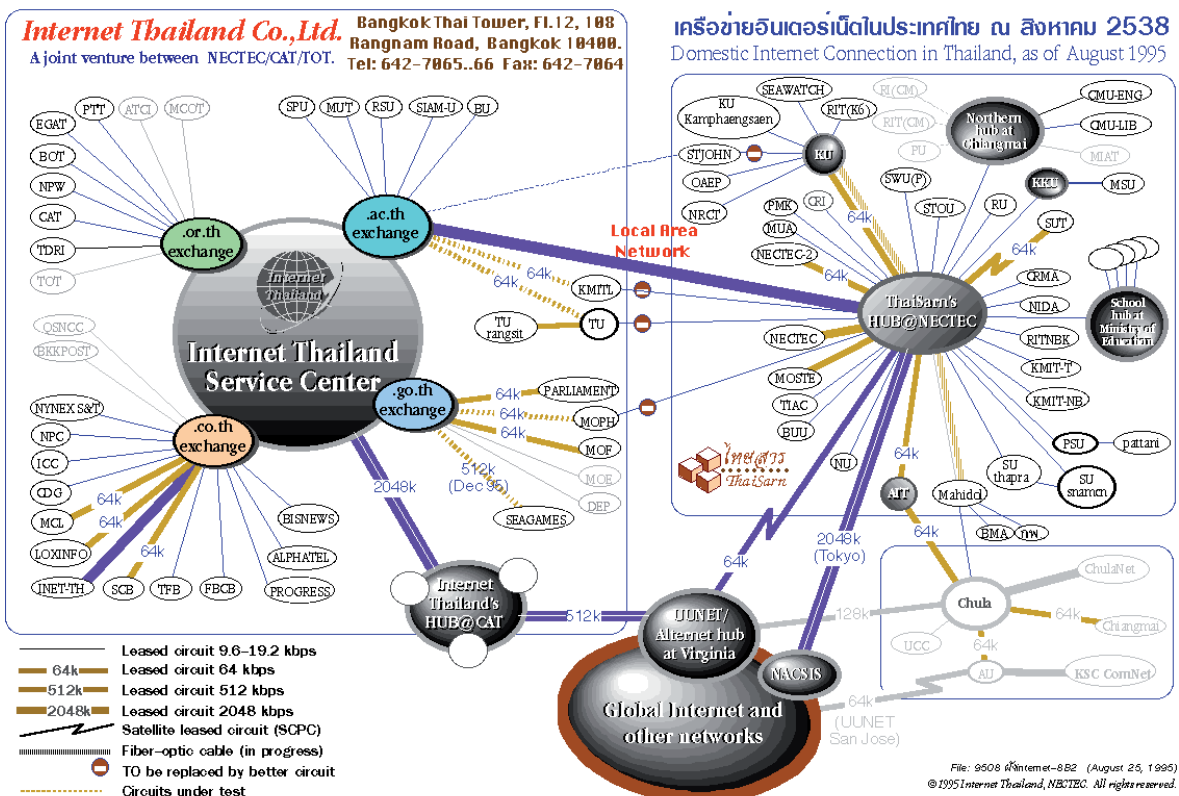

[Information Source: NECTEC]

Expanding network infrastructure in Thailand IT Year (1995)

Inter University Network (Y2006)

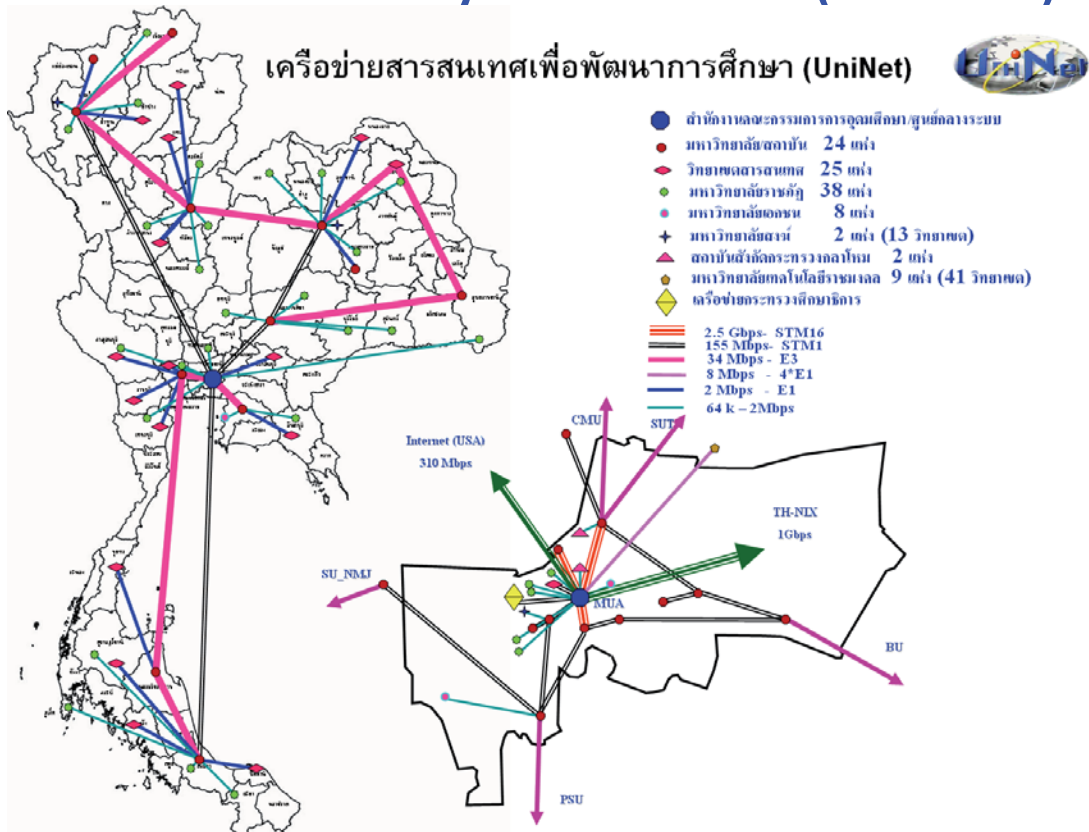

[Information Source: UniNet]

Setting up nationwide backbone network

MOE Net (Y2006)

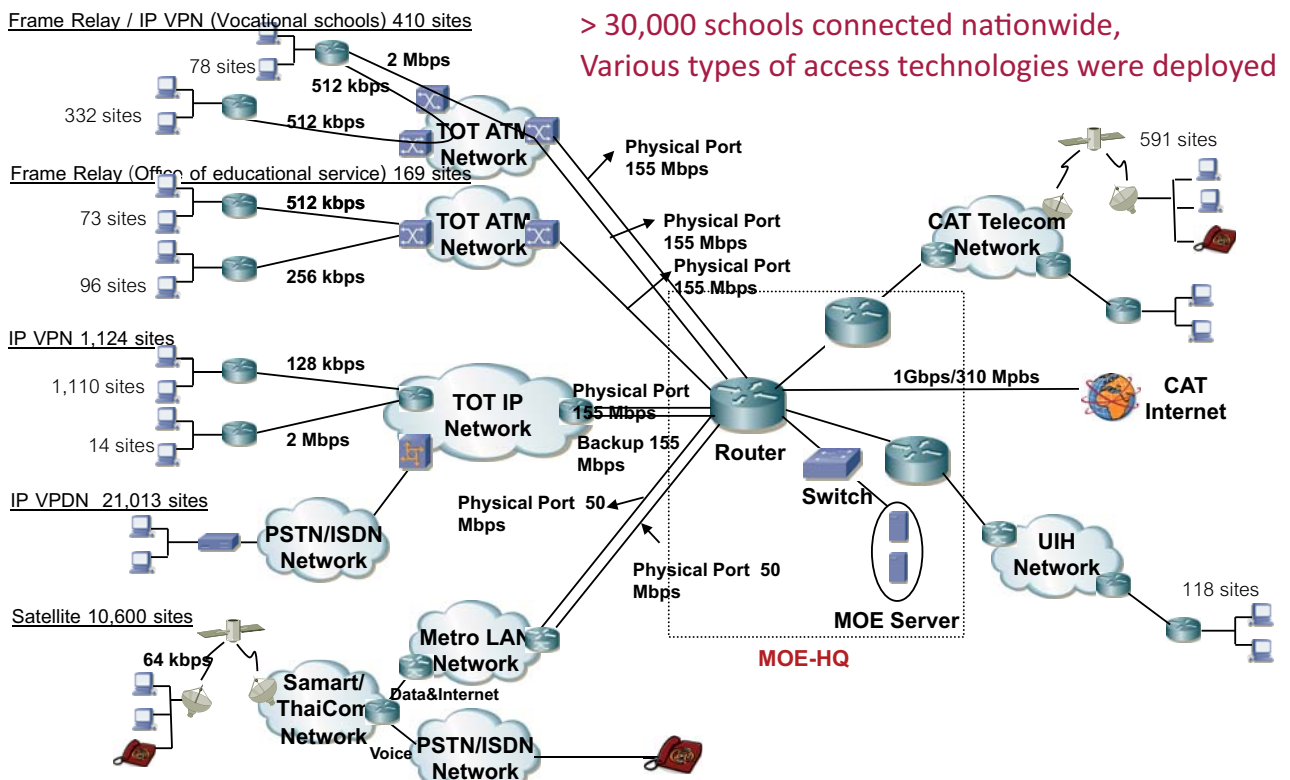

[Information Source: TOT and MOE]

Needs for High-Speed National R&E Network

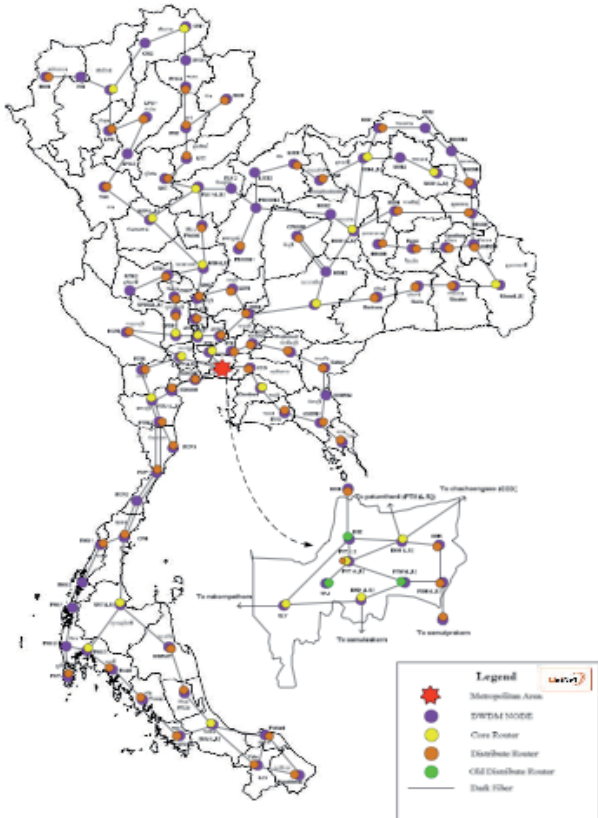

New backbone network

- Optical Network Backbone with DWDM @ N x 10Gbps
- Fiber to the University @ Gbps
- Fiber to the school @ 10 – 100 Mbps
- Public libraries @ 10 – 100 Mbps

Type	Number of Institutes
University and College	> 350
Research Center/ Institute	> 15
School	> 30,000
Others	>10



Connecting to International R&E Networks

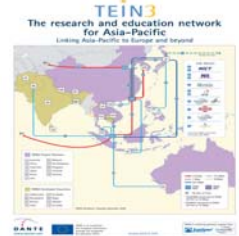
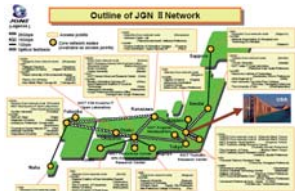
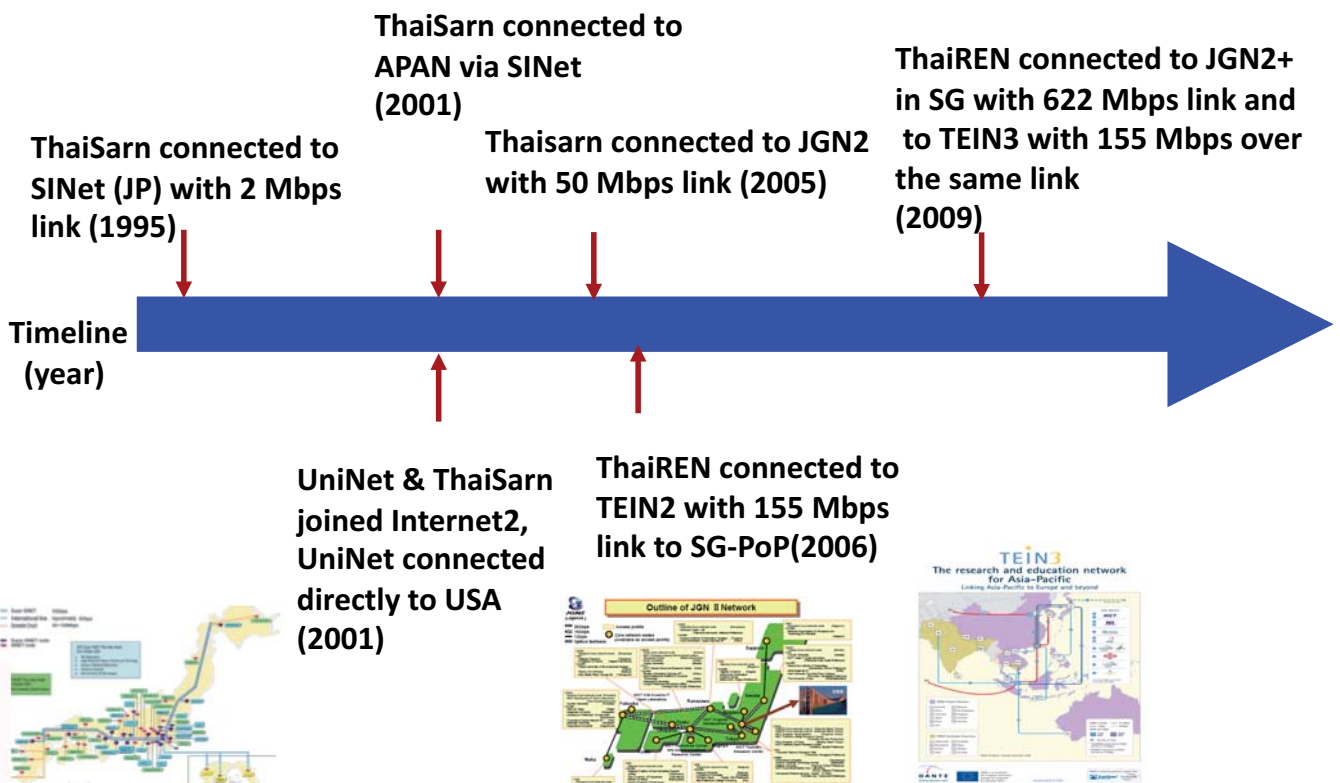

R&E Gateway to Global Collaboration

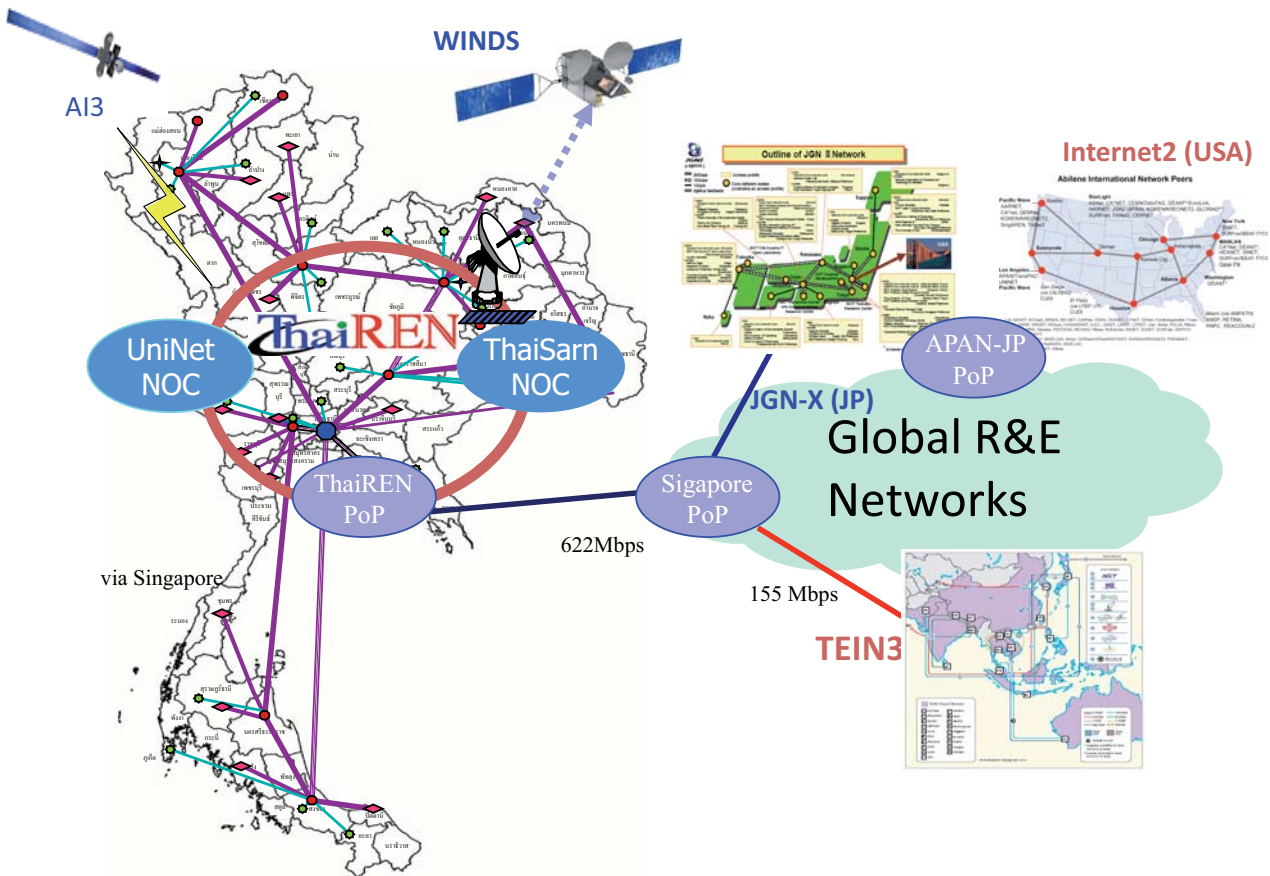

Examples of Network Services, Applications, and Project Collaborations

- IPv4/IPv6
- Teleconferencing
- E-learning
- Tele-education
- Tele-medicine
- Live video stream transmission
- Earth observation data transfer
- E-Science
- Future Internet technology

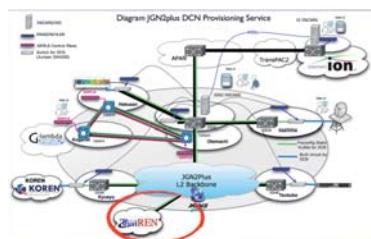
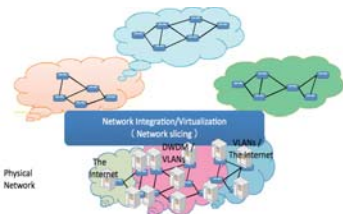

Tele-Education

- Students can attend virtual classes that look as if they are attending in the same classroom.

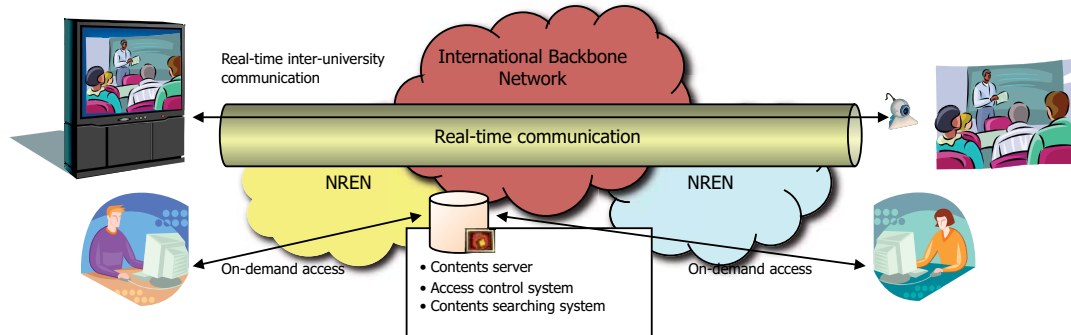

Tele-medicine

- Advanced medical treatment and diagnostic skills from specialist doctors are feasible with tele-mentoring system

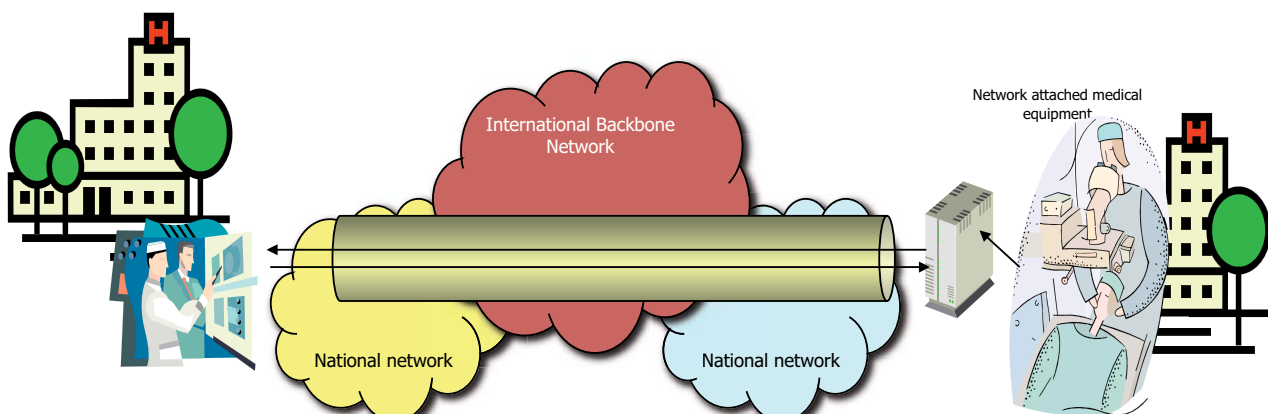

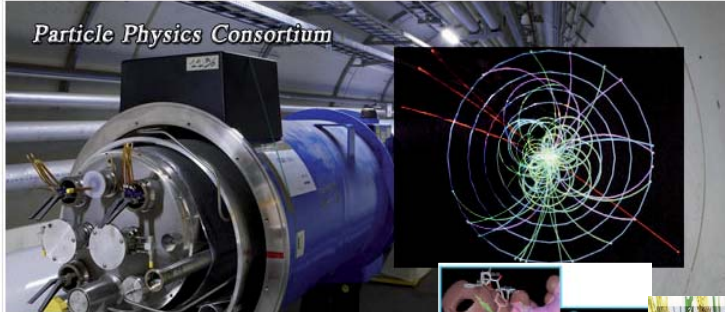
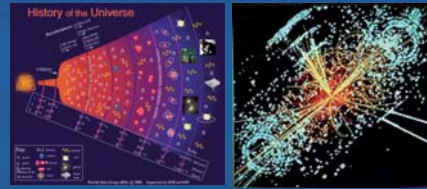

กลุ่มวิจัยสาขาฟิสิกส์อนุภาคพลังงานสูง



Hot News

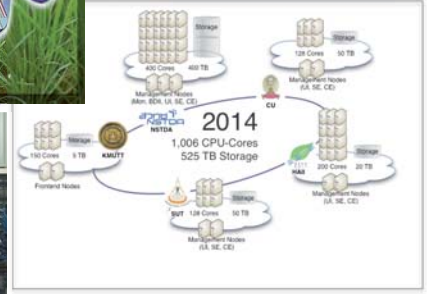

Case Study: Selecting Network Path for Project Experiment between NRENs

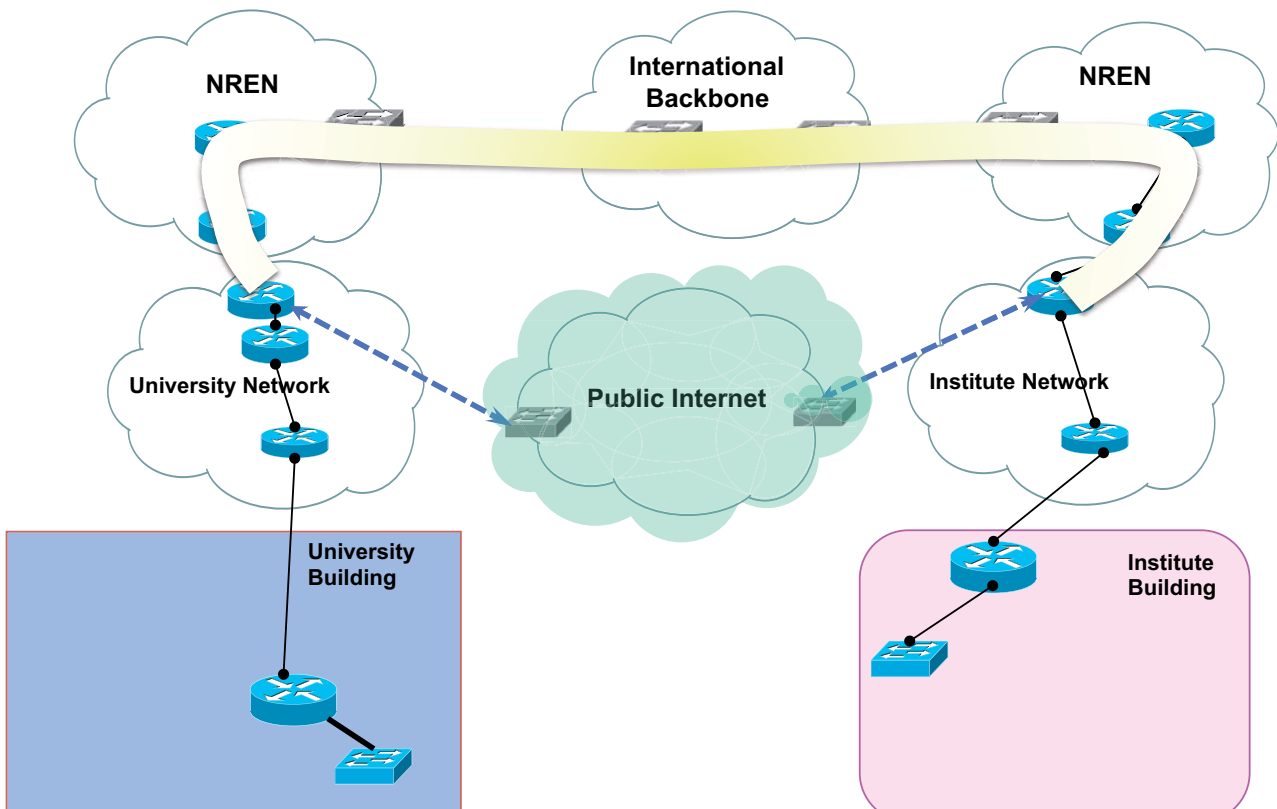

Co-operation between network engineers along the network path is important

Example of Network Paths (old diagram)

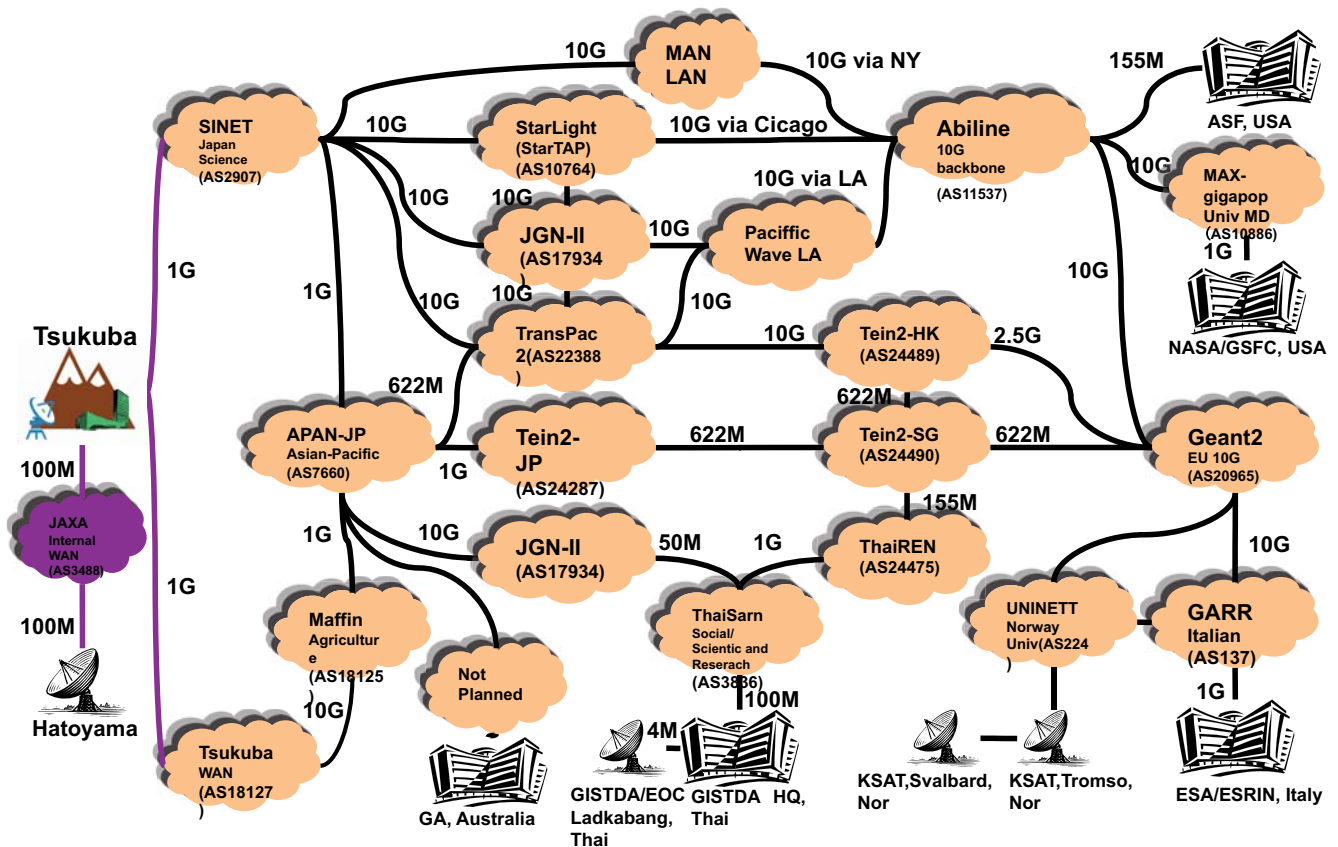

Knowledge and Experience from NREN Development

- The development of a NREN normally takes time and effort
- All types of supports from government are necessary
- Good coordination between organizations/institutes can overcome problems
- International collaboration (and support) can be a good opportunity for improvement
 - Network development for research and education activities
 - Technology and knowledge transfer through training programs and research collaborations
 - Human relationships and networking with partners through project collaborations

Summary

- National and International Research and Education Networks are important to provide network infrastructure for education and research activities
- New generation RENs will be able to support advanced research applications
- Global Collaboration is useful and and important
- Co-operations between networks/institutions are necessary to provide quality of service and assurance to network applications
- More research projects, applications and collaborations should be encouraged

Thank You



High-capacity Internet networks for Research and Education Communities

Nguyen Hong Van, Ph.D.
Director of VinaREN, Vietnam

Laos, 28 May 2012

VinaREN – the unique NREN in Vietnam

- VinaREN is the National Research and Education Network of Vietnam. It is an advanced information infrastructure that fosters nationwide and worldwide collaborations of researchers and educators communities in Vietnam.
- VinaREN was officially launched at the national scale on 27 March 2008.
- At the 23rd APAN Conference, 2007, Vietnam was officially joined APAN
- VinaREN has now developed in both breadth and depth.

VinaREN
www.vinaren.vn

Vietnam Research and Education Network – VINAREN
International and National Connectivity 5/2012

- VinaREN national backbone network is formed from the connection of six network operation centers (NOC) located in Hanoi, Danang, Ho Chi Minh City, Hue, Can Tho and Thai Nguyen.
- VinaREN connects 100+ R&E institutions in 11 provinces & Cities

National Agency for Science and Technology Information
29 Le Thanh Kien, Hanoi
ĐT số Fax 84 2022024

VinaREN

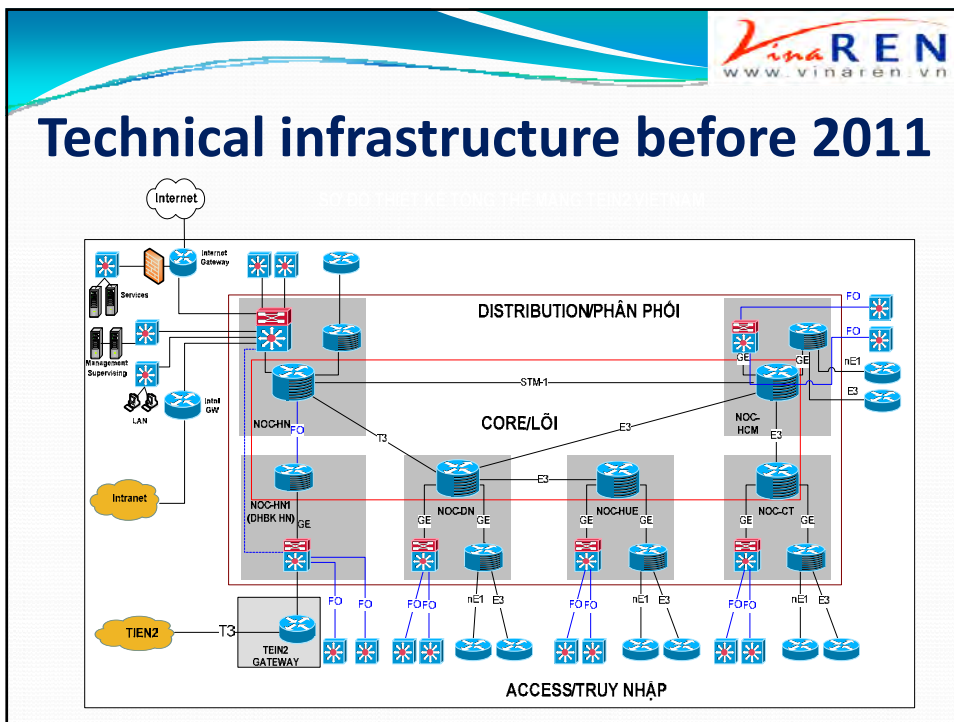

Technical infrastructure

National backbone upgraded

In 2011, VinaREN upgraded all the channels on the backbone. Currently, the bandwidth at all channels have been increased from 2 to 8 times higher than before.

- Hanoi - Ho Chi Minh: 01 Gbps;
- Hanoi - Da Nang: 155 Mbps;
- Da Nang - Hue: 155 Mbps;
- Da Nang - Ho Chi Minh City: 155 Mbps;
- Ho Chi Minh City - Can Tho: 155 Mbps;
- Hanoi - Thai Nguyen: 155 Mbps.

Technical infrastructure

Bandwidth between the NOCs and the remote members via leased line:

- Hanoi - Hai Phong: 45 Mbps
- Hanoi - Nghe An: 45 Mbps
- Da Nang - Nha Trang: 45 Mbps
- Ho Chi Minh City - Da Lat: 45 Mbps
- Can Tho - An Giang: 45 Mbps

Technical infrastructure

- Support simultaneously both IPv4 and IPv6. OSPF and BGP are used in VinaREN and to connect it with the other providers.
- The VinaREN members are connected via direct fiber optics to NOCs at the speed of Ethernet / Gigabit Ethernet through leased lines or Metro network infrastructure of Viettel telecom company.

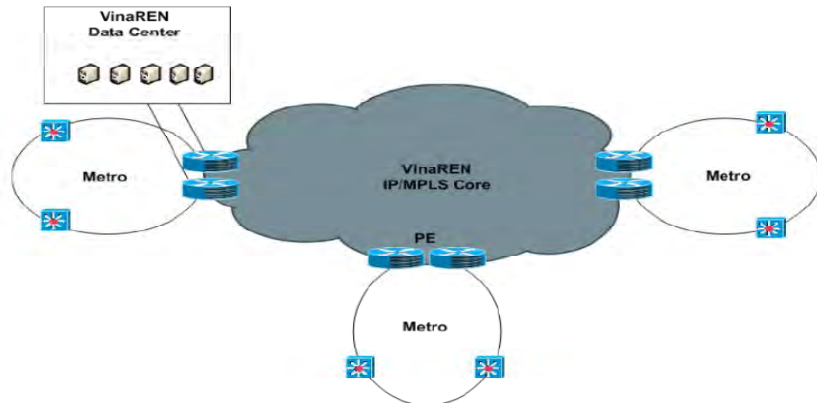

7

Technical infrastructure

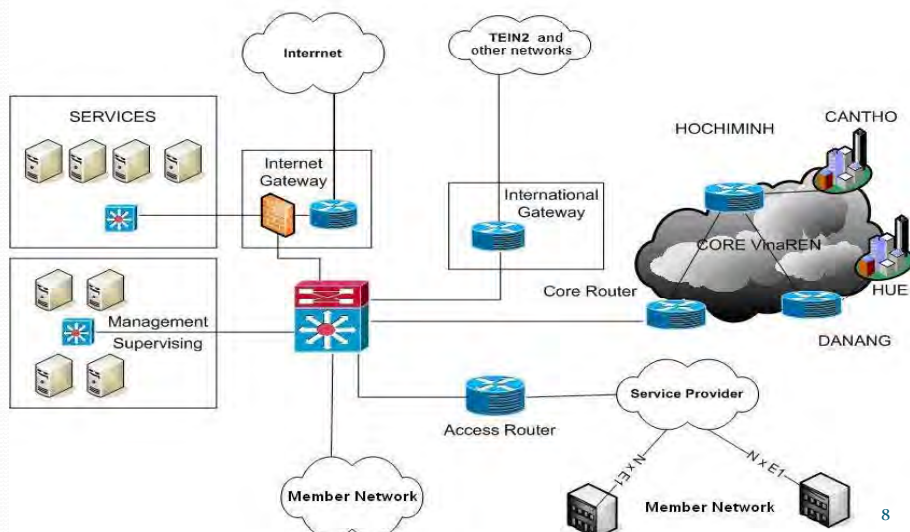

8

Communities – VinaREN Members

- **The leading universities and academic institutions:** National University in Hanoi (VNU HN), Vietnam National University in Ho Chi Minh City (VNU HCM), Hanoi University of Science and Technology, Can Tho University, and so on
- **The major R&D institutions:** Vietnam Academy of Science and Technology, Vietnam Academy of Social Sciences, Vietnam Agency of Atomic Energy.
- **The leading research hospitals:** pediatric hospital, Viet-Duc hospital, Cho Ray hospital, and so on.
- **The major institutions on climate change:** Central center for Hydro-meteorology weather forecasting, Tsunami Warning center, National Remote Sensing center, regional Hydro-meteorology stations, ...
- **The leading library & information centers:** NASATI, National Library, learning resources centers in Da Nang, Hue, Can Tho, Thai Nguyen
- **Government institutions:** MOST, Hoalac High Tech Park

Applications: E-learning

- E-learning has been used by more and more members to promote national and international cooperation programs. Hanoi National University, Hanoi University of Science and Technology, and Can Tho University have been proactively involved in E-learning.

VinaREN fosters E-learning



Lecture from UPMC, Paris, France

Applications: Telemedicine

- VinaREN-supported Telemedicine has been largely applied by major hospitals in Vietnam(Cho ray hospital, Central Pediatric hospital, Central Military hospital, Viet-Duc hospital, etc. ...) proactively using Digital Video Transmission System (DVTS) to exchange experiences between medical communities

Applications: Telemedicine

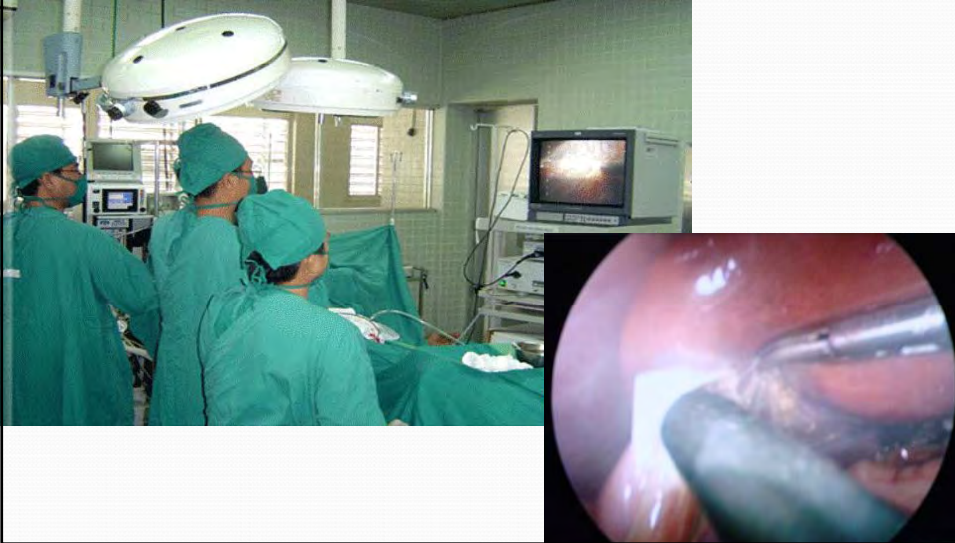

VinaREN supports Weather Forecasting & Climate Modeling

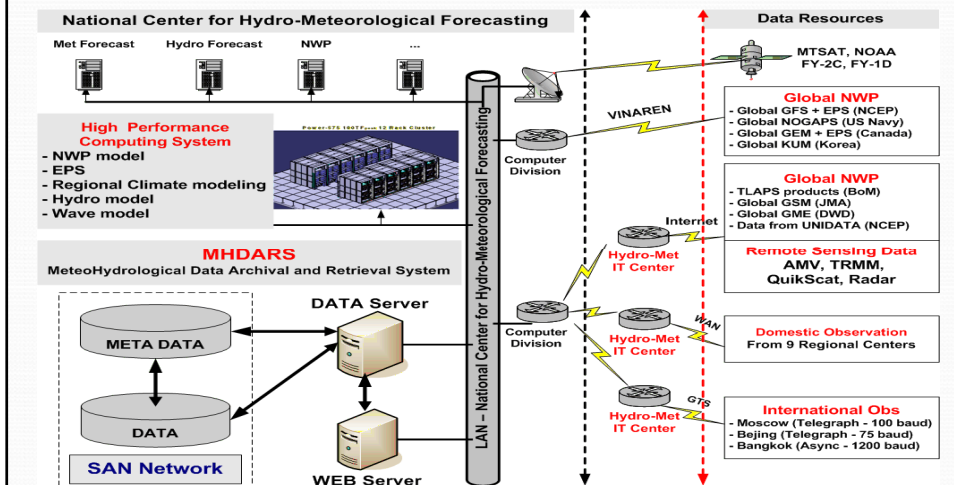

VinaREN supports Weather Forecasting & Climate Modeling

- Data exchanged over VinaREN is about 90% of the total data that National center for Hydro meteorological forecasting needs for conducting research and forecasts.
- 500 GB per day from NOAA, US-Navy, Korea, Japan
- 15 to 20 minutes per session instead of 5 to 6 hours before.
- Accuracy of short-term and medium-term weather forecasting has been improved.

VinaREN supports Weather Forecasting & Climate Modeling

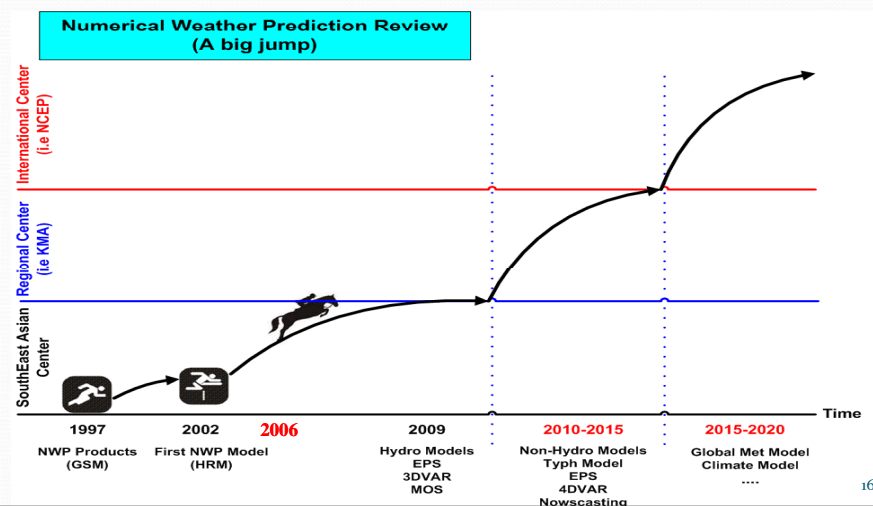

VinaREN supports Weather Forecasting & Climate Modeling

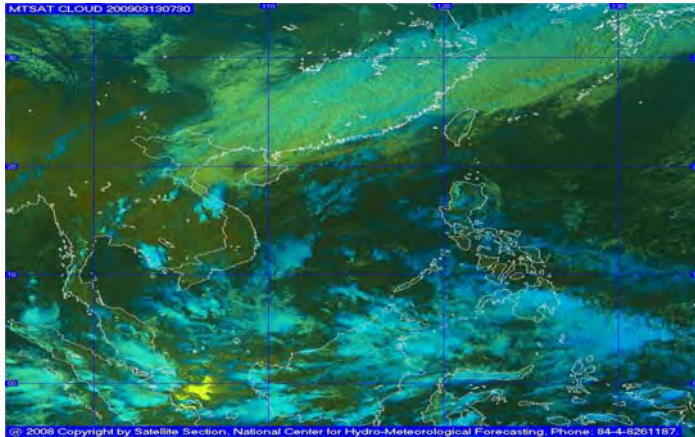

VinaREN-based international satellite sensing information network has been created to facilitate access and exchange environmental data sets, satellite images for the weather forecast and climate modeling.

Grid Computing

- Grid Computing systems can be reached in to global
- Efficient utilization of resources of different organizations
- Users do not need to know where the resources is

need to build the
Distributed
Supercomputing

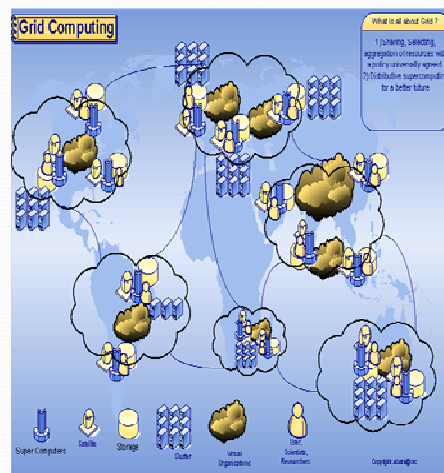

Grid Computing centers in Vietnam

- 2008: 6 centers
 - Hanoi University of Technology
 - HCM University of Technology
 - Vietnamese National University in Hanoi
 - Vietnamese Institute of Information Technology (IOIT)
 - Ha noi
 - Ho Chi Minh
 - Vietnamese Military Technical Academy (VMTA)
- 2009: one more
 - Hanoi University of Education

TEIN-3 and VinaREN network

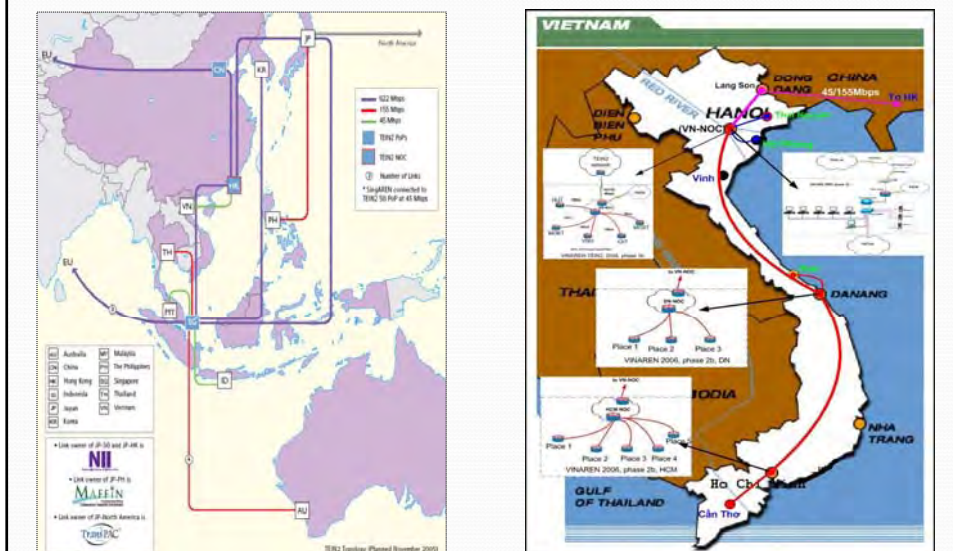

Grid computing

- VinaREN is survival condition for R&E institutions in Vietnam to conduct the researches on the grid computing.
- VinaREN supports VN-Grid's operation and participation in Pragma.
- VinaREN facilitates collaborations of existing high performance computing centers in the country.

PRAGMAGrid members

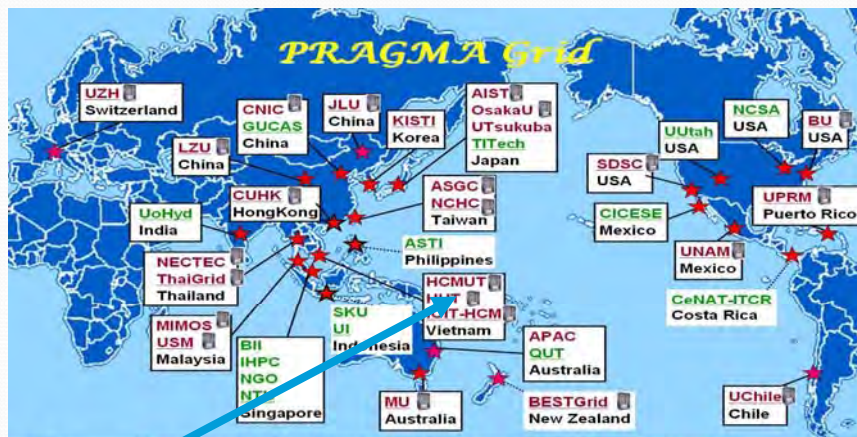

26 institutions in 17 countries/regions, 23 compute sites (+ 15 in preparation)

Last update: 9/24/2008



EUAsiaGrid Members



www.vinaren.vn

❖ Using gLite in the grid infrastructure

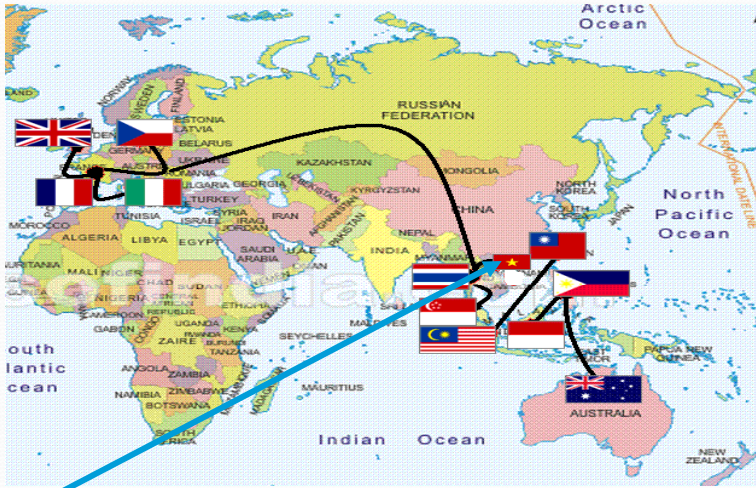

International Connections



www.vinaren.vn

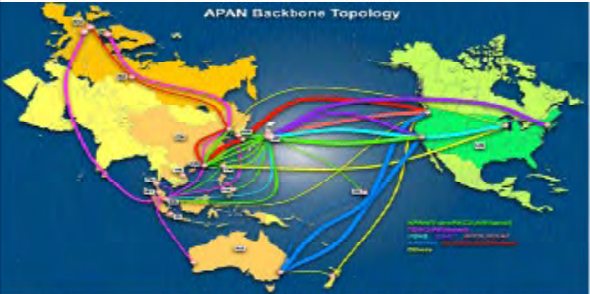

APAN Backbone Topology



TEIN3
The research and education network for Asia-Pacific
Linking Asia-Pacific to Europe and beyond

- VinaREN has been internationally connected to TEIN3 (Hanoi - Hong Kong) with a bandwidth of 155 Mbps. Through this connection, VinaREN has connections to GEANT, Internet 2 and APAN.
- In 2011, VinaREN cooperated with Viettel company to establish 100 Mbps connection for CamREN, including 10 Mbps to TEIN3 via VinaREN.
- 40 Mbps of commercial Internet for access to online databases and journals

Applications: Digital content development and sharing

- Digital library development and digital content sharing are one of important applications that VinaREN facilitates and greatly fosters.
- Domestic research database and online international scholar resources can be exchanged and shared on the VinaREN that allow R&E communities access to and use proactively.

Activities

- VinaREN supports its members in organization of online seminars, workshops, conferences and training activities with partners at home and abroad
- VinaREN supports the VN-Grid in deployment of grid computing network that facilitates national collaborations as well as participating in international project Pragma.
- VinaREN supports and trains members to implement video conferencing and DVTS.

Activities



- Cooperate with InTERLab (AIT, Thailand) and NSRC (Oregon University, U.S.) to organize international training courses on "Campus Network Design and operation" and "Multicast hand-on" for network technicians coming from 9 different countries in December 2011.

Future Plans

- Promote activities of working groups: telemedicine, climate change, grid computing, e-learning and network engineering, etc. ...
- Implement new technologies such IPv6, Multicast, etc...
- Promote information resources sharing among VinaREN members
- Upgrade connection HN – Hongkong to TEIN₄ by 622 Mbps
- Connect VinaREN to GLORIAD by 1 Gbps via Singapore;
- Continue supporting CamREN to connect to TEIN_{3/4} via VinaREN;

Future Plans

- Expand the connectivity of VinaREN to 50% of R&E institutions by the year 2015 and to 100% of ones by the year 2020
- Cooperate with InTERLab (AIT, Thailand) and APNIC to organize international training courses on "Basic Routing" for network technicians of TEIN₃ members in June 2012 at VinaREN - Hanoi.
- As a member of TEIN₂/TEIN₃ and APAN, VinaREN participated and contributed actively in the framework of cooperative projects.

Thank you

**High-capacity internet networks for
research and education communities
TEIN3 Workshop
28th May 2012, Lao Plaza Hotel, Vientiane, Lao PDR**

Current Lao ICT Infrastructure

By Khamla Sounnalat
Dy. Director General, Lao National Internet Center
Ministry of Posts and Telecommunications

Agenda

- Country profile
- Telecommunication Services in Lao.PDR
- Internet Services in Lao.PDR
- MPT Organization Chart
- Lao National Internet Center
- The existing National Transmission Network

➤ Country profile

3

About Laos



Country Name	Lao People's Democratic Republic
Area	236,800 KM2
Capital City	Vientiane Capital
Population	6.5 Millions
Official language	Lao language
GDP per capita	US\$ 965 ; GDP growth 8 %
Currency	Kip (US\$ = 7950 Kip)
Time Zone	UTC +7
Calling code	+856
ccTLD	.la
Telecom Regulator	Ministry of Posts and Telecommunications (MPT) http://www.mpt.gov.la
PSTN	3 Operators (LTC, ETL, STL)
Mobile	4 Operators (LTC, ETL, STL, VCL)
ISPs	6 ISPs

4

➤ Telecommunication Services in Lao.PDR

5

Operators and ISPs in Laos

Name	Describe
Lao Telecom Co (LTC)	Established in 1996 Lao Government 51% and Thaicom (Thailand) 49%
ETL Public Company (Enterprise Telecom Lao)	Re-established in 2000 State-owned company, Lao Government 100% ETL will sell first 30% IPO on November 2011 (delay), Government will continue to hold 70%.
Star Telecom Lao (STL)	Established in 2008 Lao Asia Telecom 51% and Viettel Global (Vietnam) 49% Started the new brand "Unitel" on October 2009.
VimpelCom Lao (Beeline)	Established in 2003, (re-established in 2011) Lao Government 22% and VimpelCom 78% VimpelCom (Russia) bought 78% shares from Millicom International Cellular (MIC) on March 2011
Planet Online	Established in 1997 Lao Private Company
Sky Telecom	Established in 2005 Lao Government 30% and Sky Telecom Thailand 70% Sky Telecom Thailand withdraw the investment in beginning of 2011, and now restructuring under Ministry of Defense (MOD)

6

PSTN and Mobile Statistics

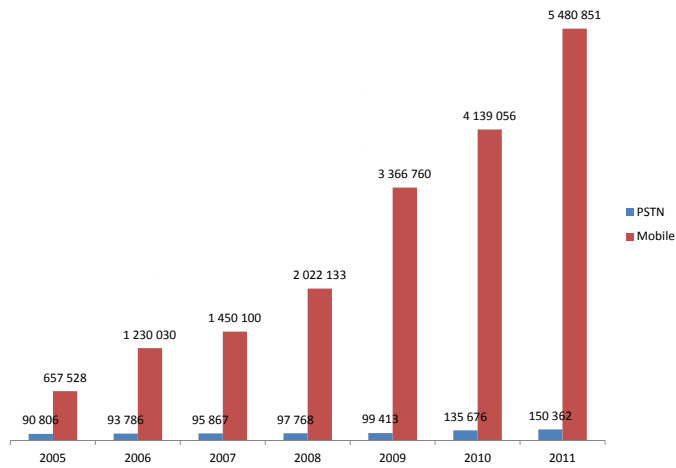

Like other developing countries, the mobile penetration is growing rapidly. Mobile phone penetration is about 83% of Lao population

7

Mobile Market Share

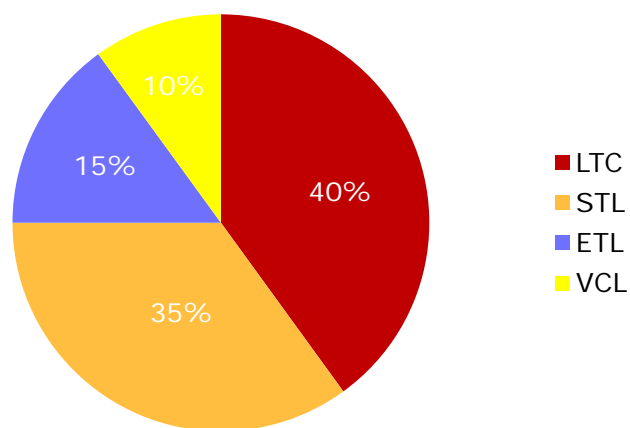

Total 5.4 millions mobile subscribers (2011)

8

➤ Internet Services in Lao.PDR

9

Internet Service Providers in Laos

Name	Wire	Wireless
Lao Telecom Co (LTC)	ADSL	3.5G (HSDPA)
Enterprise Telecom Lao (ETL)	ADSL	3.5G (HSDPA)
Star Telecom Lao (Unitel)	ADSL	3.5G (HSDPA)
VimpelCom Lao (Beeline)	No	3.5G (HSDPA), WiMAX
Planet Online	No	WiMAX
Sky Telecom	(Restructuring)	(Restructuring)

<http://www.laotel.com/>
<http://www.etllao.com.la/>
<http://www.unitel.com.la/>
<http://www.beeline.la/> (<http://www.tigolao.com>)
<http://www.laopdr.com/>
<http://www.laosky.com/>

10

Internet subscribers

Type	2008	2009	2010	2011
ADSL	13,200	15,600	18,800	25,000
IPSTAR (Satellite)	311	305	204	189
Leased line	-	53	70	88
3.5G (HSDPA)	-	-	> 10,000	> 20,000

There internet penetration in Laos is about 5% of population

11

➤ MPT Organization Chart

12

Ministry of Posts and Telecommunications

- In October 2007, National Authority of Posts and Telecommunications (NAPT) devised from Ministry of Communication, Transportation, Post and Construction (MCTPC)
- In June 2011, National Authority of Posts and Telecommunications becomes Ministry of Posts and Telecommunications (MPT)



13

Organization Chart of MPT

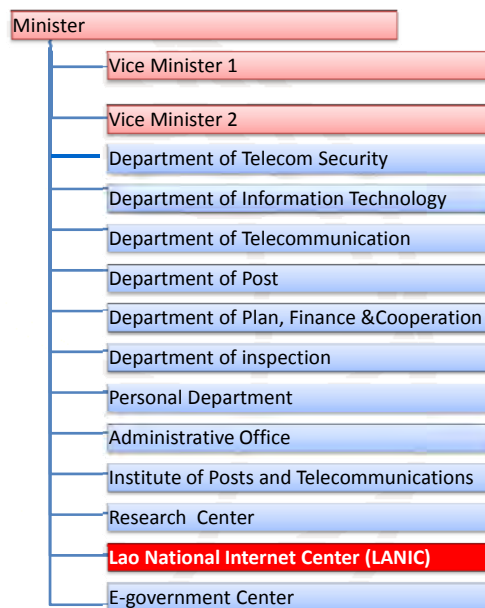

14

Lao National Internet Center

- Lao National Internet Center Project was established under decree number 716/PMO (22/4/2008).
- LANIC is under the MPT and manage as Carrier neutral and Not-for-profit organization.
- LANIC responsible for connecting with oversea carriers for IP transit and monitoring International Internet Gateway.
- LANIC will be a registry for dot LA ccTLD.

15

International Internet Gateway

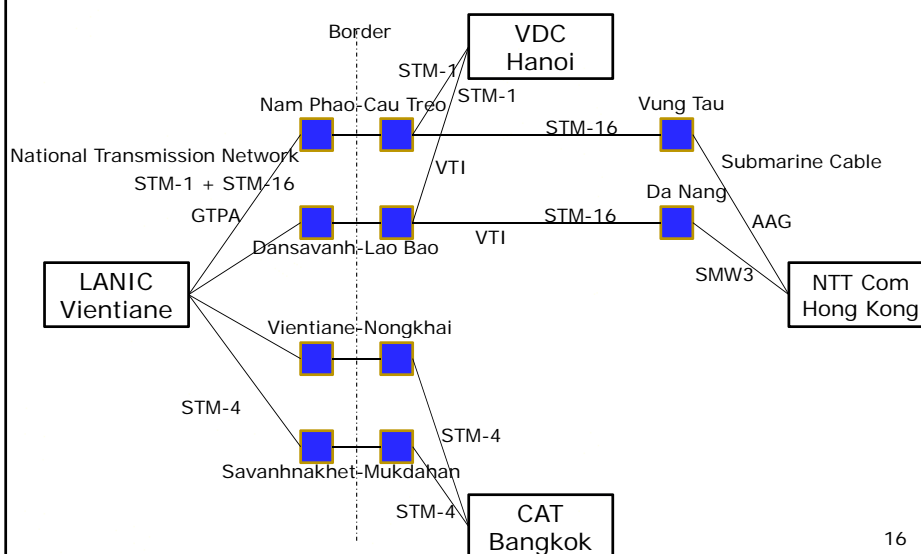

16

➤ The Existing National Transmission Network

17

National Transmission Network

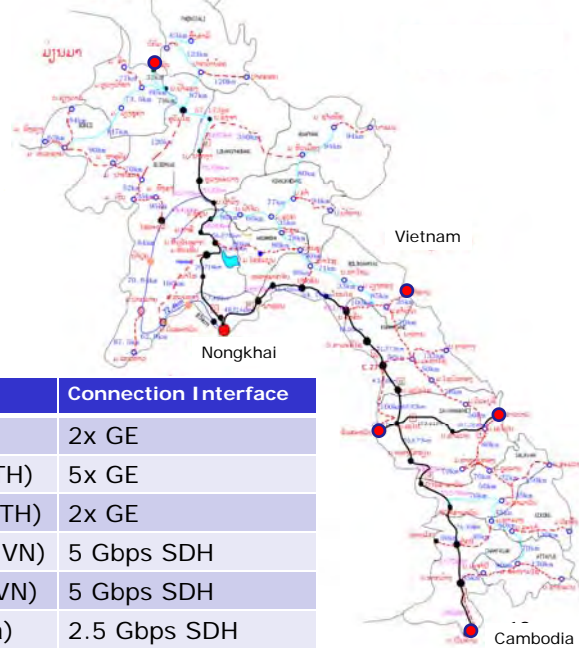

National Transmission Network connect to Ministry of Education.

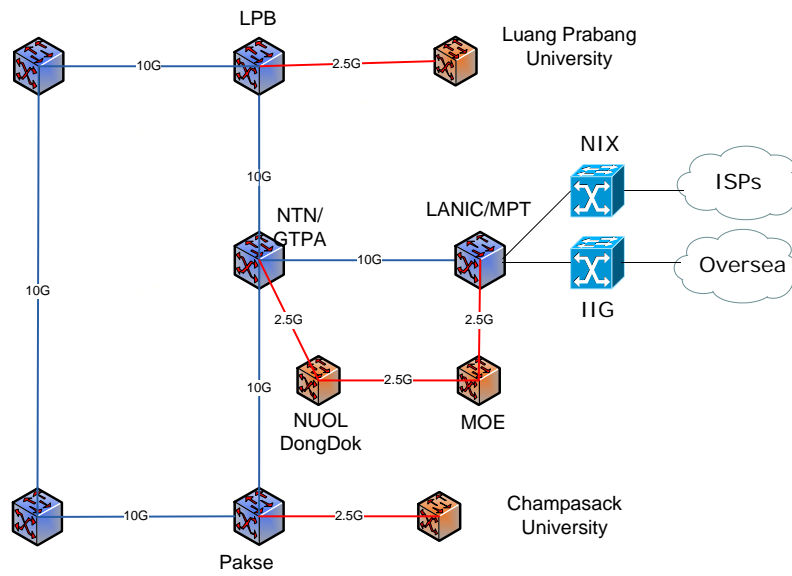

19

Thank you !

20

TEIN 3 Workshop

May 28, 2012 at Lao Plaza

Status and Development on ICT for/in Education:

“Using of ICTs to Improve the Quality of and Access to
Education”

Associate Professor Dr. Somkiat PHASY
Ministry of Education

OUTLINE

- ▶ Introduction
- ▶ Project: Using of ICTs to Improve the Quality of and Access to Education
- ▶ Further Project Design and Development
- ▶ Conclusion
- ▶ Questions and Recommendations

INTRODUCTION

- ▶ Lao PDR – Least Developing Country
- ▶ Status of Laos on IT knowledge & Application for/in Education
 - Microsoft Office, e-mail, searching data sources, Preparation for running the curriculum program (1996), Research & Education Network
 - Laos in the Third Group of 11 SEAMEO Member Countries
- ▶ National Policies
 - 2020, Reduce Poverty & Bring Country out of LD Status as well as to Industrialization and Modernization
 - 2015, meet MDG

INTRODUCTION (*Continue*)

- ▶ Government Approval of National Education Reform:
 - Standardize Educational System
 - Improvement of Educational Quality & its Equal access
 - Bringing ICT Application to Curriculum Program
- ▶ Using of ICTs: ICT become is increasingly become priority factors for all Sector:
 - E-Government Project
 - National ICT Policy
 - Telecommunication Sector
 - Banking Sector

INTRODUCTION (*Continue*)

- ▶ Using of ICTs: ICT become is increasingly become priority factors for all Sector:
 - **ICT at University Level:**
 - Research and Education Network,
 - Running Curriculum Program: Bachelor Program(2004)
 - CONE Project
 - TEIN
 - ASEAN Cyber University
 - So on
 - **Macro Level:**
 - Project: Using of Its to Improve the Quality of and Access to Education
 - SHEP: Laos University Management System in 3 Universities
 - Government Notice: Centralize ICT for/in Education

Project: Using of ICTs to Improve the Quality of and Access to Education

- ▶ **Goals:**
 - Access to highly qualified standard lectures, e-books & information for all students
 - Knowledge sharing, Interactive learning techniques
 - Remote classrooms, Video conferencing, Learning at home
 - Fast, low cost educational administration
 - Linking schools to wider ICT community including library
 - ▶ **Project Objectives:**
 - To improve the ICT Infrastructure for Education Sector
 - To improve the quality of education services
 - To improve the education administration and management capability
- Human Resource Development and Capacity Building

Project: Using of ICT...

▶ Scope of Supply

- IT Infrastructure system: network system, data center, terminals and offices: Fiber Optic Links
- Interactive educational system
- E-learning system
- Surveillance system

▶ Project Development

- Central IT Center–Data Center, Office, Classrooms
- 17 standardized modern schools – Data center & Classrooms: PC lab, Physical, chemical & biological labs, traditional classrooms, e-library room, e-language room, lecture and teleconference rooms, staff offices, studio room, server rooms & IT technician rooms.

Project: Using of ICT...

▶ Scope of Services: Educational Information–Communication Infrastructure (EII):

- ICT facilities for students, staff & teachers' ICT knowledge training
- Multimedia devices for new education delivery
- ICT facilities for school administration & learning management system
- Campus LAN network with LAN & WLAN
- Voice & data communication infrastructure linking education ministry offices, IT center, 17 Model schools, educational department in 17 provinces & surrounding schools

Project: Using of ICT...(Continue)

▶ Network Model Overviews

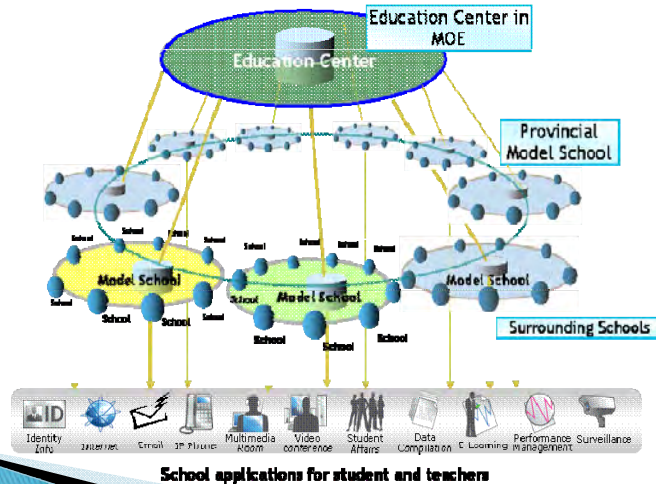

Project: Using of ICT...(Continue)

▶ Interactive Education System Overviews

Generic Structure Topology of Distance Education

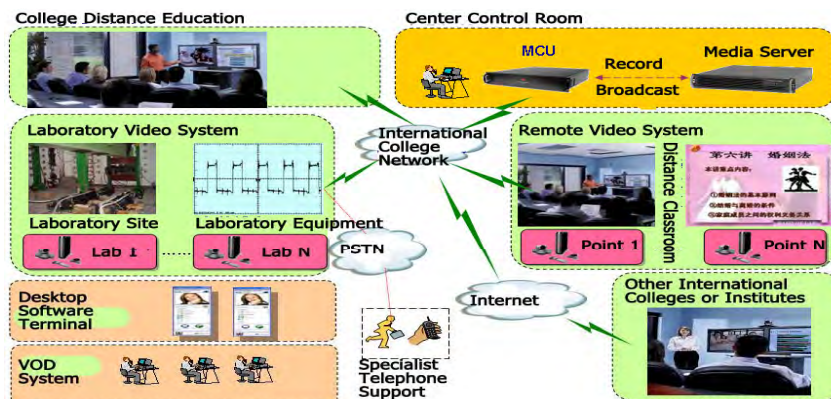

Project: Using of ICT...(Continue)



Project: Using of ICT...(Continue)

► MIS of Education System Overview

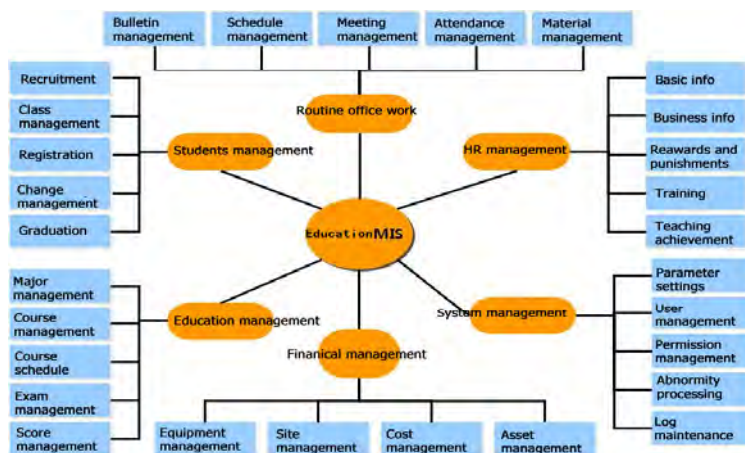

FURTHER PROJECT DEVELOPMENT

► Full Scope of ICT Application in Education expected for Laos:

◦ **Issue 1:**

- Model 1: Teaching Learning CD-Rom & Playing Station
- Model 2: Educational Satellite Receiving & Playing Station
- Model 3: Computer Classroom with Internet

Extension to all other school levels, in remote areas?

Extension to Technical Colleges, Teacher Training Colleges & university levels?

FURTHER PROJECT DEVELOPMENT

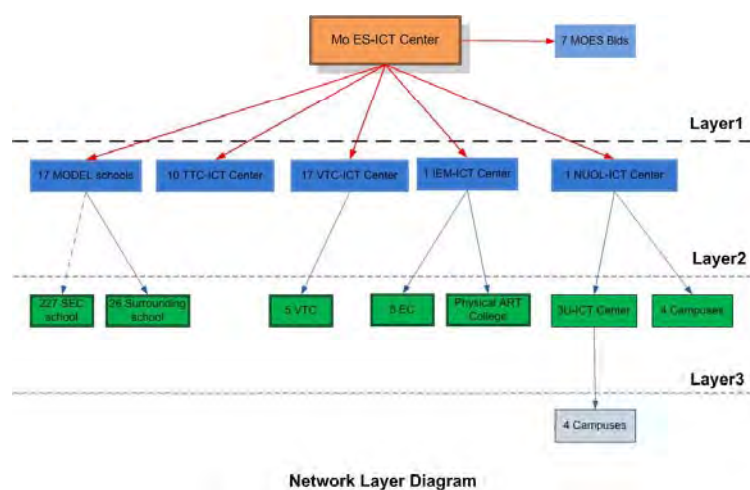

FURTHER PROJECT DEVELOPMENT

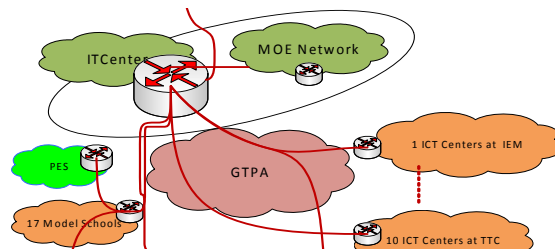

FURTHER PROJECT DEVELOPMENT

▶ Issue 2:

- Institutional framework
 - ICT Policy for/in Education
 - ICT Master Plan for/in Education
 - Regulation on ICT Infrastructure operation, management & maintenance?

▶ Issue 3:

- Teachers training on how to not only use Microsoft Office only, but more personal web, designing uploading teaching materials.
- Pedagogical teacher training on Content Development

FURTHER PROJECT DEVELOPMENT

- ▶ **Issue 4:**
 - Link, share & manage the data source and information with other sectors
- ▶ **Issue 5:**
 - Database for the whole Education Sector linked all together? Completed Data set?, That is very important for optimal utility of ICT resources in its potential manners,
- ▶ **Issue 6:**
 - National Research and Education Network
- ▶ **Issue 7:**
 - Community Learning Centers for Remote Districts

Conclusion

- ▶ Since ICT as an important tool is increasingly become priority factor for each sector, particularly for Education sector there is wide rank of use, management and high cost of maintenance and more over, we still learn on what work and what does not.....
- ▶ Working together closely!!!
- ▶ Moving with the same direction: Vectors Polarized?

Thank you for Attention!!!
Thanks & Appreciations for
Questions, suggestion &
Recommendations???